



Specialized High Quality

Woodworking Cutter



Prompt delivery. Quality assured. For details and specifications please visit our website.

www.tongfong.com.tw



Helical Planing Cutter (with throw-away T.C.T tips)

AM814



Accessories	Size(mm)
	14 X 14 X 2
	13 X 12 X 11
	M8 X 18
	4 X 100

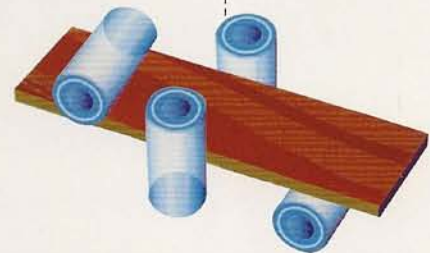
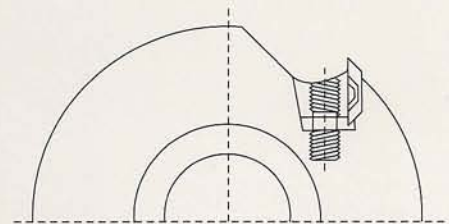

- Material : Light alloy body (Aluminium)
- Suitable for Four sides moulder, copy shapers, spindle shapers.
- Suitable materials : solid wood, plywood, acryl, MDF
- Special specifications is available as per custom's order

Helical Planing Cutter (With throw-away T.C.T tips)

ITEM No.	ϕ D mm	B mm	ϕ d mm	Z
AM814 100060	100	60	30/31.75/35/40	6
AM814 100080	100	80	30/31.75/35/40	6
AM814 100100	100	100	30/31.75/35/40	6
AM814 100130	100	130	30/31.75/35/40	6
AM814 100155	100	155	30/31.75/35/40	6
AM814 100180	100	180	30/31.75/35/40	6
AM814 125060	125	60	40/50	6
AM814 125080	125	80	40/50	6
AM814 125100	125	100	40/50	6
AM814 125130	125	130	40/50	6
AM814 125155	125	155	40/50	6
AM814 125180	125	180	40/50	6
AM814 125200	125	200	40/50	6
AM814 125230	125	230	40/50	6
AM814 125255	125	255	40/50	6
AM814 125300	125	300	40/50	6
AM814 125320	125	320	40/50	6

Helical Planing Cutter (with throw-away T.C.T tips)

AM615

AM615 Helical Planing Cutter



Accessories	Size(mm)
	15 X 15 X 2.5
	M6 X 15
	5 X 100

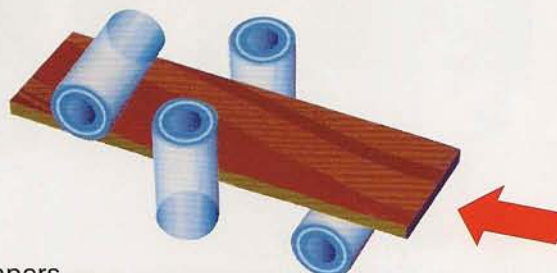

- Material : Light alloy body (Aluminium)
- Suitable for Four sides moulder, copy shapers, spindle shapers.
- Suitable materials : solid wood, plywood, acryl, MDF
- Special specifications is available as per custom's order

Helical Planing Cutter



ITEM No.	ϕ D mm	B mm	ϕ d mm	Z
AM615 100080	100	80	30/31.75/35/40	6
AM615 100100	100	100	30/31.75/35/40	6
AM615 100130	100	130	30/31.75/35/40	6
AM615 100150	100	150	30/31.75/35/40	6
AM615 100180	100	180	30/31.75/35/40	6
AM615 125080	125	80	40/50	6
AM615 125100	125	100	40/50	6
AM615 125130	125	130	40/50	6
AM615 125150	125	150	40/50	6
AM615 125180	125	180	40/50	6
AM615 125200	125	200	40/50	6
AM615 125230	125	230	40/50	6
AM615 125250	125	250	40/50	6
AM615 125300	125	300	40/50	6
AM615 125320	125	320	40/50	6

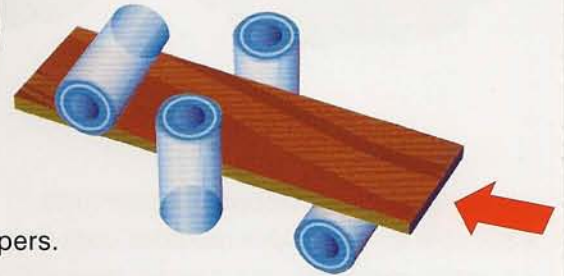
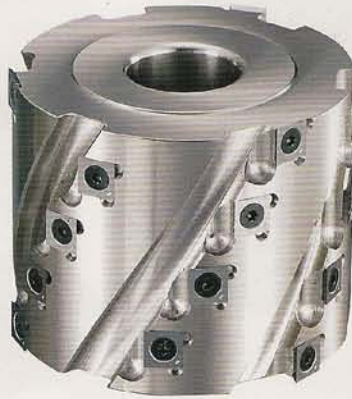

Helical Planing Cutter (with throw-away T.C.T tips)

SM615



Accessories	Size(mm)
	15 X 15 X 2.5
	M6 X 15
	5 X 100

- Material : steel body
- Suitable for Four sides moulder, copy shapers, spindle shapers.
- Suitable materials : solid wood, plywood, acryl, MDF
- Special specifications is available as per custom's order

Helical Planing Cutter

ITEM No.	ϕ D mm	B mm	ϕ d mm	Z
SM615 100080	100	80	30/31.75/35/40	6
SM615 100100	100	100	30/31.75/35/40	6
SM615 100130	100	130	30/31.75/35/40	6
SM615 100150	100	150	30/31.75/35/40	6
SM615 100180	100	180	30/31.75/35/40	6
SM615 125080	125	80	40/50	6
SM615 125100	125	100	40/50	6
SM615 125130	125	130	40/50	6
SM615 125150	125	150	40/50	6
SM615 125180	125	180	40/50	6
SM615 125200	125	200	40/50	6
SM615 125230	125	230	40/50	6
SM615 125250	125	250	40/50	6
SM615 125300	125	300	40/50	6
SM615 125320	125	320	40/50	6

SM615 Helical Planing Cutter



Helical Planing Cutter (with throw-away T.C.T tips)

AM1030

AM1030 Helical Planing Cutter

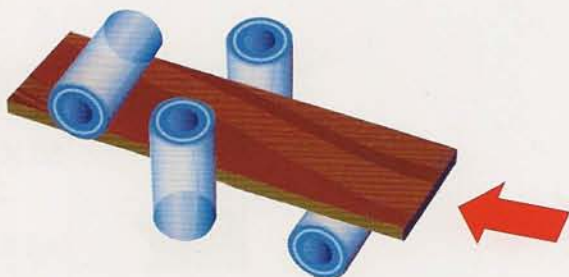
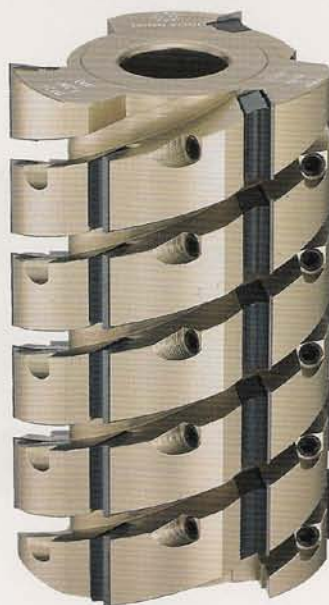

- Material : Light alloy body (Aluminium)
- Suitable for Four sides moulder
- Suitable materials : solid wood, plywood, acryl, MDF
- Special specifications is available as per custom's order

Accessories	Size(mm)
	30 X 12 X 1.5
	28 X 18 X 10
	M10 X 20
	5 X 100

Helical Planing Cutter

ITEM No.	ϕ D mm	B mm	ϕ d mm	Z
AM1030 125100	125	100	40/50	6
AM1030 125130	125	130	40/50	6
AM1030 125155	125	155	40/50	6
AM1030 125180	125	180	40/50	6
AM1030 125200	125	200	40/50	6
AM1030 125230	125	230	40/50	6
AM1030 125250	125	250	40/50	6
AM1030 125300	125	300	40/50	6
AM1030 125320	125	320	40/50	6



Planing Cutter Head (with throw-away T.C.T tips)

AM1050

AM1050 Planing Cutter Head

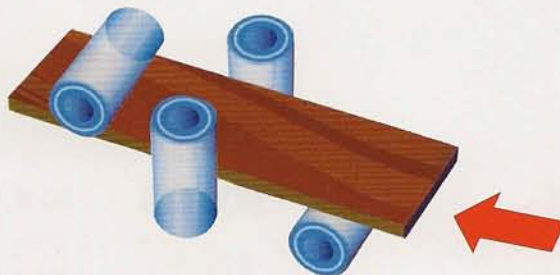

- Material : Light alloy body (Aluminium)
- Suitable for Four sides moulder
- Suitable materials : solid wood, plywood, acryl, MDF
- Special specifications is available as per custom's order

Accessories	Size(mm)
 Knife	50 X 12 X 1.5
 Wedge	48 X 16 X 10
 Screw	M10 X 20
 Screwdriver	5 X 100

Planing Cutter Head

ITEM No.	ϕ D mm	B mm	ϕ d mm	Z
AM1050 125100	125	100	40/50	9
AM1050 125130	125	130	40/50	9
AM1050 125150	125	150	40/50	12
AM1050 125180	125	180	40/50	15
AM1050 125200	125	200	40/50	15
AM1050 125230	125	230	40/50	15
AM1050 125250	125	250	40/50	21
AM1050 125300	125	300	40/50	21
AM1050 125320	125	320	40/50	21



Planing Cutter Head (with throw-away T.C.T tips)

SM1050

SM1050 Planing Cutter Head

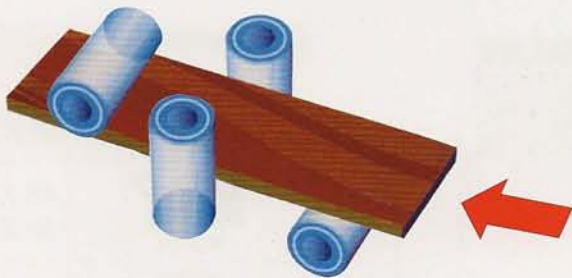

- Material : Steel body
- Suitable for Four sides moulder
- Suitable materials : solid wood, plywood, acryl, MDF
- Special specifications is available as per custom's order

Accessories	Size(mm)
 Knife	50 X 12 X 1.5
 Wedge	48 X 16 X 10
 Screw	M10 X 20
 Screwdriver	5 X 100

Planing Cutter Head

ITEM No.	ϕ D mm	B mm	ϕ d mm	Z
SM1050 125100	125	100	40/50	9
SM1050 125130	125	130	40/50	9
SM1050 125150	125	150	40/50	12
SM1050 125180	125	180	40/50	15
SM1050 125200	125	200	40/50	15
SM1050 125230	125	230	40/50	15
SM1050 125250	125	250	40/50	21
SM1050 125300	125	300	40/50	21
SM1050 125320	125	320	40/50	21



Planing Cutter Head (with throw-away T.C.T tips)

AM5

AM5 Planing Cutter Head

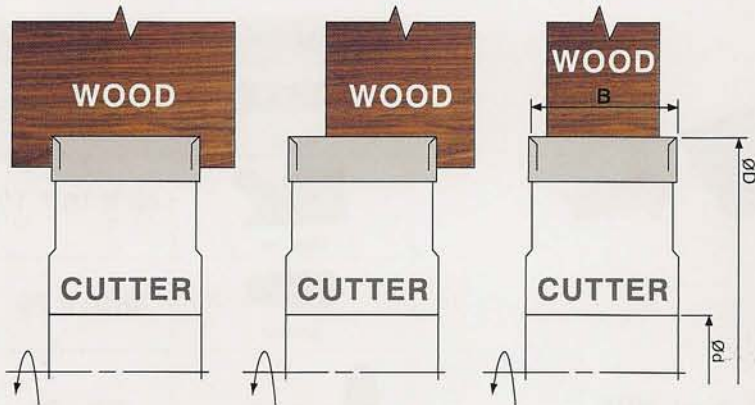
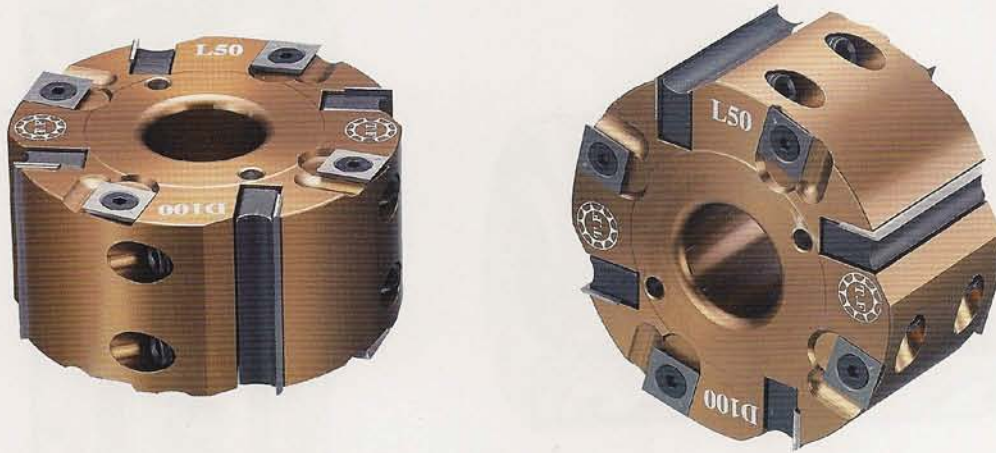

- Material : Light alloy body (Aluminium)
- Suitable for Four sides moulder, copy shapers, spindle shapers.
- Suitable materials : solid wood, plywood, acryl, MDF
- With spur

Accessories	Size(mm)
Knife	50 X 12 X 1.5 30 X 12 X 1.5
Wedge	48 X 16 X 10 28 X 16 X 10
Spur	14 X 14 X 2
Screw	M10 X 20
Screw	M5 X 10
Screwdriver	3 X 100 5 X 100

Planing Cutter Head

ITEM No.	ϕ D mm	B mm	ϕ d mm	Z	V
AM5 10030	100	30	30/31.75/35/40	4	4 / 8
AM5 10050	100	50	30/31.75/35/40	4	4 / 8
AM5 12530	125	30	30/31.75/35/40	4	4 / 8
AM5 12550	125	50	30/31.75/35/40	4	4 / 8



Assembler Planing Cutter Head (with throw-away T.C.T tips)

AM10

AM10 Assembler Planing Cutter Head

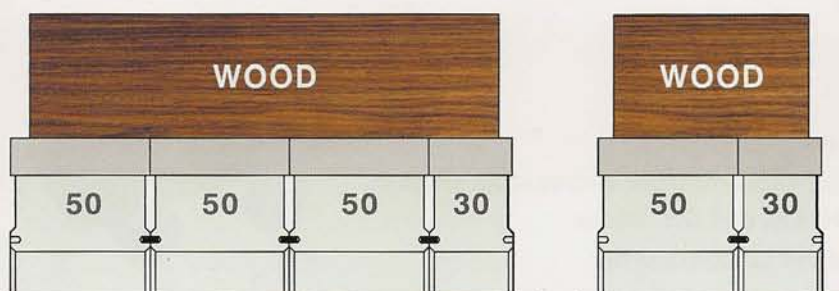

Accessories	Size(mm)
 Knife	50 X 12 X 1.5 30 X 12 X 1.5
 Wedge	48 X 16 X 10 28 X 16 X 10
 Screw	M10 X 20
 Screwdriver	5 X 100

- Material : Light alloy body (Aluminium)
- Suitable for Four sides moulder, copy shapers, spindle shapers.
- Suitable materials : solid wood, plywood, acryl, MDF

Assembler Planing Cutter Head

ITEM No.	ϕ D mm	B mm	ϕ d mm	Z
AM10 10030	100	30	30/31.75/35/40	4
AM10 10050	100	50	30/31.75/35/40	4
AM10 12530	125	30	30/31.75/35/40	4
AM10 12550	125	50	30/31.75/35/40	4



Planing Cutter Head AM1230

AM1230 Planing Cutter Head



Accessories	Size(mm)
	H X 30 X 3
	H X 24 X 12
	6 X 100
	M10 X 25 M12 X 29
	

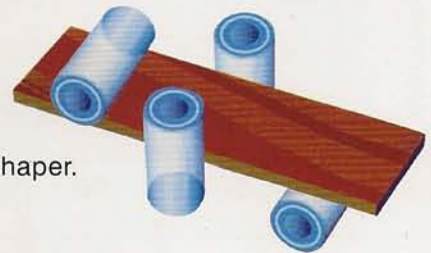
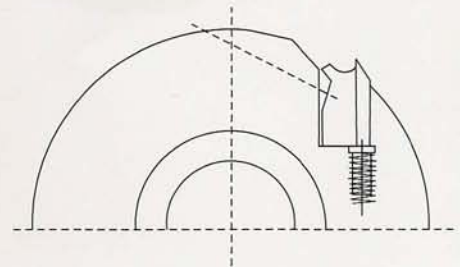

- Material : Light alloy body (Aluminium)
- Suitable for Three sides moulder, Four sides moulder and spindle shaper.
- The material for the blade could be H.S.S. or T.C.T. Blade.
- Special specifications is available as per custom's order.

Planing Cutter Head

ITEM No.	ϕ D mm	B mm	ϕ d mm	Z
AM1230 100080	100	80	30/31.75/35/40	4
AM1230 100100	100	100	30/31.75/35/40	4
AM1230 100130	100	130	30/31.75/35/40	4
AM1230 125080	125	80	40/50	4
AM1230 125100	125	100	40/50	4
AM1230 125130	125	130	40/50	4
AM1230 125150	125	150	40/50	4
AM1230 125180	125	180	40/50	4
AM1230 125200	125	200	40/50	4
AM1230 125230	125	230	40/50	4
AM1230 125250	125	250	40/50	4
AM1230 125300	125	300	40/50	4
AM1230 125320	125	320	40/50	4

Planing Cutter Head

SM1230



Accessories	Size(mm)
	H X 30 X 3
	H X 24 X 12
	6 X 100
	M12 X 29
	

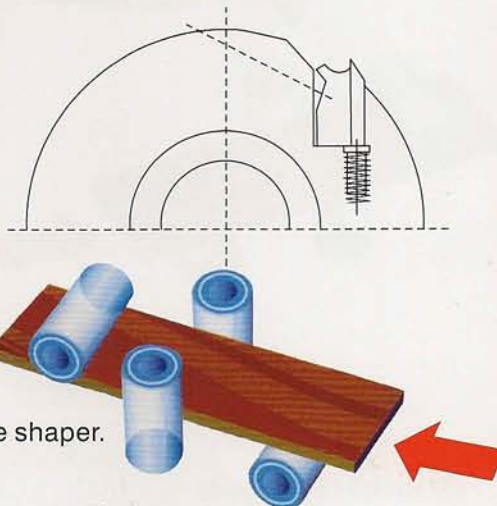

- Material : Steel
- Suitable for Three sides moulder, Four sides moulder and spindle shaper.
- The material for the blade could be H.S.S. or T.C.T. Blade.
- Special specifications is available as per custom's order.

Planing Cutter Head

ITEM No.	ϕ D mm	B mm	ϕ d mm	Z
SM1230 125050	125	50	40/50	4
SM1230 125060	125	60	40/50	4
SM1230 125080	125	80	40/50	4
SM1230 125100	125	100	40/50	4
SM1230 125130	125	130	40/50	4
SM1230 125150	125	150	40/50	4
SM1230 125180	125	180	40/50	4
SM1230 125200	125	200	40/50	4
SM1230 125230	125	230	40/50	4
SM1230 125250	125	250	40/50	4
SM1230 125300	125	300	40/50	4
SM1230 125320	125	320	40/50	4



Safety Corrugate Cutter Head SM1070

SM1070 Safety Corrugate Cutter Head

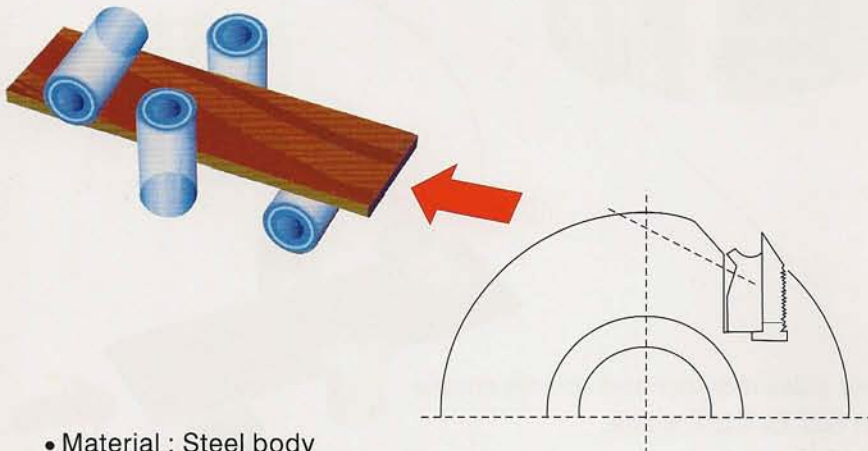
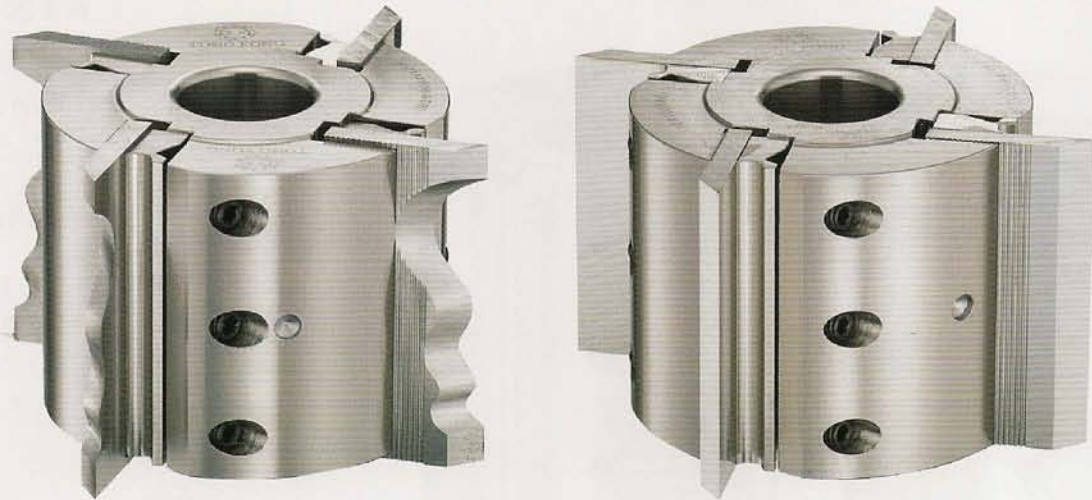

- Material : Steel body
- Suitable for Four sides moulder (H.S.S. knife) .
- Special specifications is available as per custom's order.

Accessories	Size(mm)
	H X 50-70 X 8
	H X 24 X 12
	M10 X 25
	5 X 100

Safety Corrugate Cutter Head

ITEM No.	ϕ D mm	B mm	ϕ d mm	Z
SM1070 122050	122	50	40/50	4
SM1070 122060	122	60	40/50	4
SM1070 122080	122	80	40/50	4
SM1070 122100	122	100	40/50	4
SM1070 122130	122	130	40/50	4
SM1070 122150	122	150	40/50	4
SM1070 122180	122	180	40/50	4
SM1070 122200	122	200	40/50	4
SM1070 122230	122	230	40/50	4



Helical Planing Cutter For Double-side Planer

(with throw-away T.C.T tips)

SM8100635/SAM12320

SM8100635

- Customers' request on the size of the axis on both ends are applicable.
- Suitable for Single side planer, Double side planer.

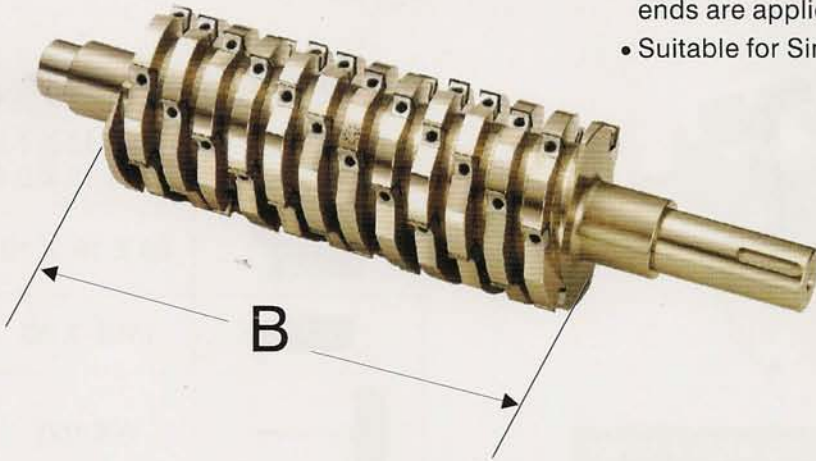

Helical Planing Cutter For Double-side Planer

ϕ D mm	B mm	Z
100-180	300-635	6/8/10

Accessories	Size(mm)
	14 X 14 X 2 15 X 15 X 2.5 14.6 X 14.6 X 2.5
	13 X 12 X 11
	M8 X 18
	4 X 100

Cutter Setting Attachment

SM12320

- Adjustment capacity : D100-300mm Width : 50-320mm





SM10125635/SM680635

Helical Planing Cutter For Double-side Planer (with throw-away T.C.T tips)

SM10125635

- Customers' request on the size of the axis on both ends are applicable.
- Suitable for Single side planer, Double side planer.

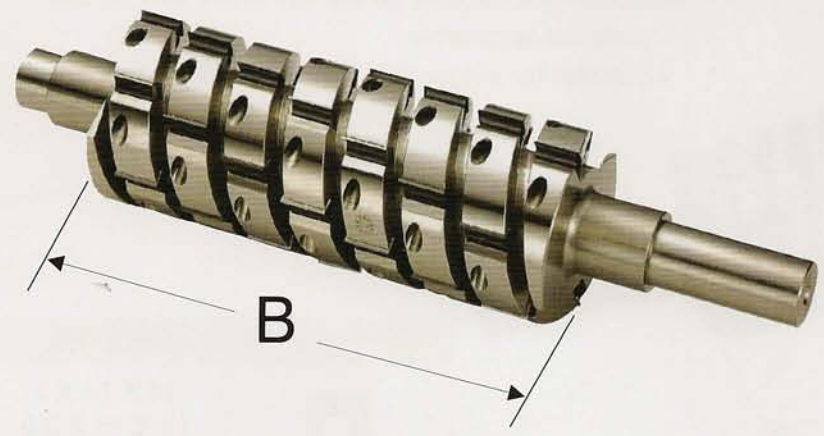

Accessories	Size(mm)
	30 X 12 X 1.5 30 X 12 X 2.5
	28 X 18 X 10
	M10 X 20
	5 X 100

Helical Planing Cutter For Double-side Planer		
ϕ D mm	B mm	Z
120-180	300-635	6/8

Helical Planing Cutter For Double-side Planer (with throw-away T.C.T tips)

SM680635

- Customers' request on the size of the axis on both ends are applicable.
- Suitable for Single side planer, Double side planer.

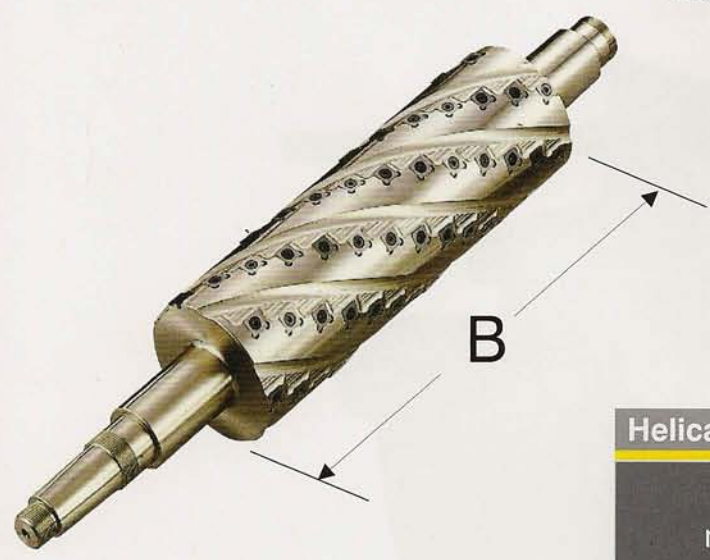

Accessories	Size(mm)
	14 X 14 X 2 15 X 15 X 2.5 14.6 X 14.6 X 2.5
	M6 X 15

Helical Planing Cutter For Double-side Planer		
ϕ D mm	B mm	Z
80-180	300-635	4/6/8/10/12



Helical Planing Cutter (Brazed T.C.T=4mm)

W1225

W1225 Helical Planing Cutter

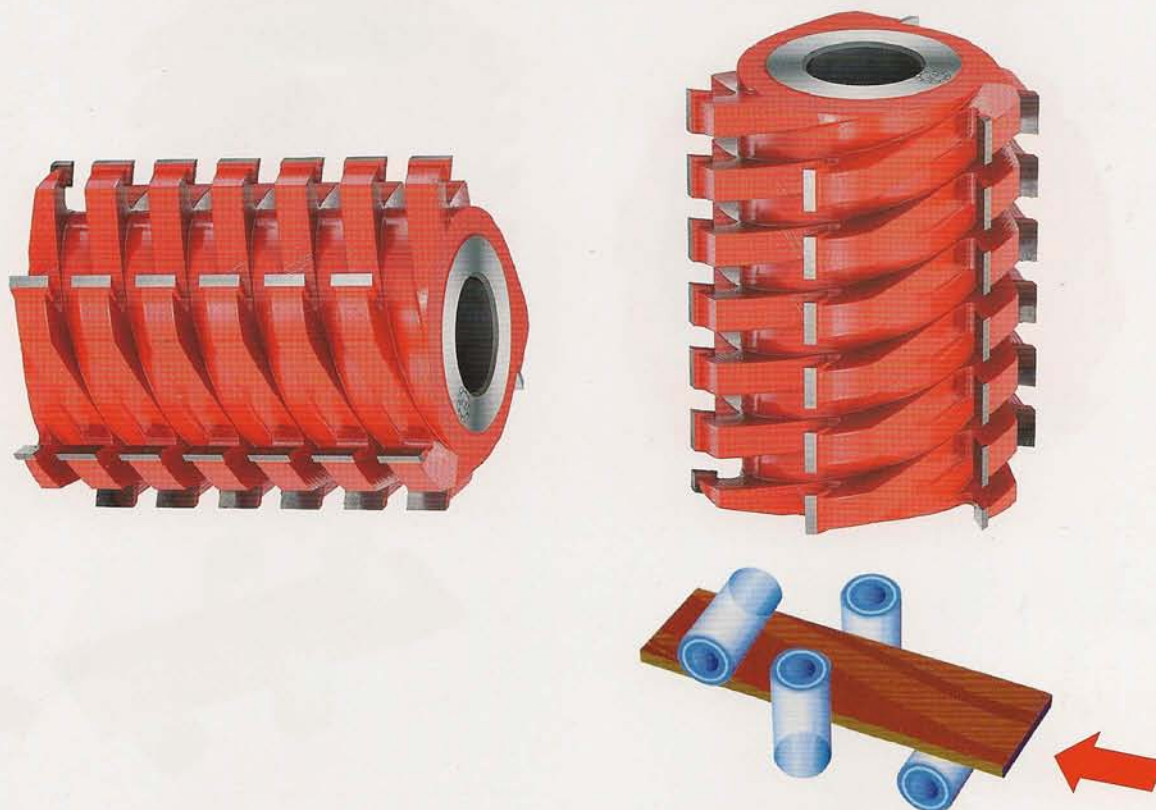

- Suitable for Three sides moulder, Four sides moulder and spindle shaper Copy shaper.
- TCT welded Helical Planing cutter.
- Suitable for heavy cutting with low noise.
- Special specifications is available as per custom's order.

Helical Planing Cutter					
ITEM No.	ϕ D mm	B mm	ϕ d mm	Z	
W1225 100060	100	60	25.4/30/31.75/35/40	6/8	
W1225 100080	100	80	25.4/30/31.75/35/40	6/8	
W1225 100100	100	100	25.4/30/31.75/35/40	6/8	
W1225 100130	100	130	25.4/30/31.75/35/40	6/8	
W1225 100150	100	150	25.4/30/31.75/35/40	6/8	
W1225 125080	125	80	40/50	6/8	
W1225 125100	125	100	40/50	6/8	
W1225 125130	125	130	40/50	6/8	
W1225 125150	125	150	40/50	6/8	
W1225 125180	125	180	40/50	6/8	
W1225 125200	125	200	40/50	6/8	
W1225 125230	125	230	40/50	6/8	



Helical Planing Cutter (Braze T.C.T)

W1218

W1218 Helical Planing Cutter



- Suitable for Three sides moulder, Four sides moulder and spindle shaper Copy shaper.
- TCT welded Helical Planing cutter.
- Suitable for heavy cutting with low noise.
- Special specifications is available as per custom's order.

Helical Planing Cutter					
ITEM No.	ϕ D mm	B mm	ϕ d mm	Z	
W1218 100060	100	60	25.4/30/31.75/35/40	8/10	
W1218 100080	100	80	25.4/30/31.75/35/40	8/10	
W1218 100100	100	100	25.4/30/31.75/35/40	8/10	
W1218 100130	100	130	25.4/30/31.75/35/40	8/10	
W1218 100150	100	150	25.4/30/31.75/35/40	8/10	
W1218 125080	125	80	40/50	8/10/12	
W1218 125100	125	100	40/50	8/10/12	
W1218 125130	125	130	40/50	8/10/12	
W1218 125150	125	150	40/50	8/10/12	
W1218 125180	125	180	40/50	8/10/12	
W1218 125200	125	200	40/50	8/10/12	
W1218 125230	125	230	40/50	8/10/12	



Planing Cutter Head (Braze T.C.T=4mm)

TF501

TF501

Planing Cutter Head



- Suitable for Three sides moulder, Four sides moulder and spindle shaper Copy shaper.
- TCT welded Helical Planing cutter.

Planing Cutter Head

ITEM No.	ϕ D mm	B mm	ϕ d mm	Z
TF501 100050	100	50	25.4/30/31.75/35/40	4
TF501 100080	100	80	25.4/30/31.75/35/40	4
TF501 100100	100	100	25.4/30/31.75/35/40	4
TF501 100130	100	130	25.4/30/31.75/35/40	4
TF501 125050	125	50	40/50	4
TF501 125080	125	80	40/50	4
TF501 125100	125	100	40/50	4
TF501 125130	125	130	40/50	4
TF501 125150	125	150	40/50	4
TF501 125180	125	180	40/50	4
TF501 125200	125	200	40/50	4
TF501 125230	125	230	40/50	4
TF501 125250	125	250	40/50	4
TF501 125300	125	300	40/50	4
TF501 125320	125	320	40/50	4



Round Rod Milling Cutter

TF502

(Braze T.C.T=4mm)



- Suitable for Four sides moulder. Round rod milling machine.
- Special specifications is available as per customs' order.

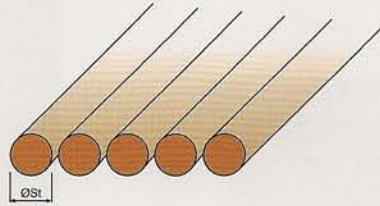
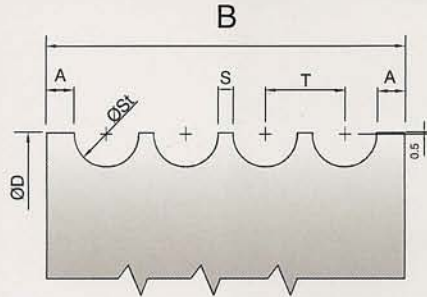

Round Rod Milling Cutter

ϕ st mm	ϕ D mm	B	ϕ d mm	S	T	A	Z
4	100/130	75mm-150mm	30/40	1	5	5	4
5	100/130	75mm-150mm	30/40	1	6	5	4
6	100/130	75mm-150mm	30/40	1	7	5	4
7	100/130	75mm-150mm	30/40	1	8	5	4
8	100/130	75mm-150mm	30/40	1	9	5	4
9	100/130	75mm-150mm	30/40	1	10	5	4
10	110/130	75mm-150mm	30/40	1.5	11.5	5	4
11	110/130	75mm-150mm	30/40	1.5	12.5	5	4
12	110/130	75mm-150mm	30/40	1.5	13.5	5	4
13	110/130	75mm-150mm	30/40	1.5	14.5	5	4
14	110/130	75mm-150mm	30/40	1.5	15.5	5	4
15	110/140	75mm-150mm	30/40	1.5	16.5	5	4
16	110/140	75mm-150mm	30/40	1.5	17.5	6	4
17	110/140	75mm-150mm	30/40	1.5	18.5	6	4
18	110/140	75mm-150mm	30/40	1.5	19.5	6	4
19	110/140	75mm-150mm	30/40	1.5	20.5	6	4
20	110/140	75mm-150mm	30/40	2	22	6	4
21	110/140	75mm-150mm	30/40	2	23	6	4
22	110/140	75mm-150mm	30/40	2	24	6	4
23	120/150	75mm-150mm	30/40	2	25	6	4
24	120/150	75mm-150mm	30/40	2	26	6	4
25	120/150	75mm-150mm	30/40	2	27	6	4
26	120/150	75mm-150mm	30/40	2	28	6	4
27	120/150	75mm-150mm	30/40	2	29	6	4
28	120/150	75mm-150mm	30/40	2	30	6	4
29	120/150	75mm-150mm	30/40	2	31	6	4
30	120/150	75mm-150mm	30/40	2	32	6	4

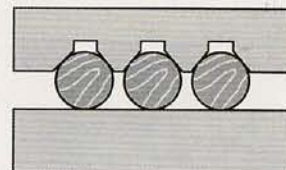
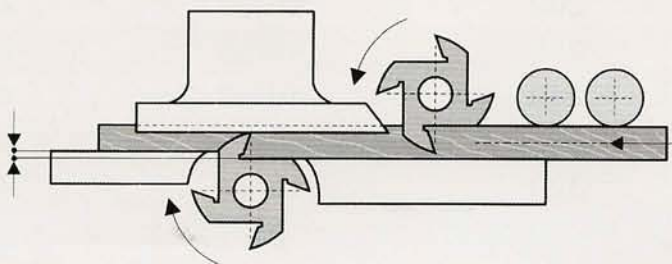

Round Rod Milling Cutter

TF503

(Braze T.C.T=4mm)

- Suitable for Four sides moulder. Round rod milling machine.
- Special specifications is available as per customs' order.

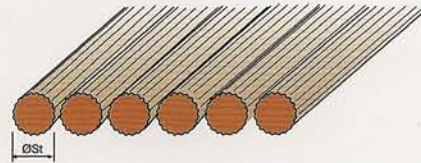
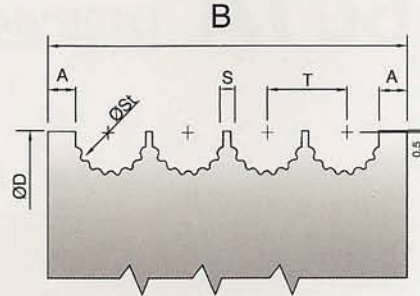
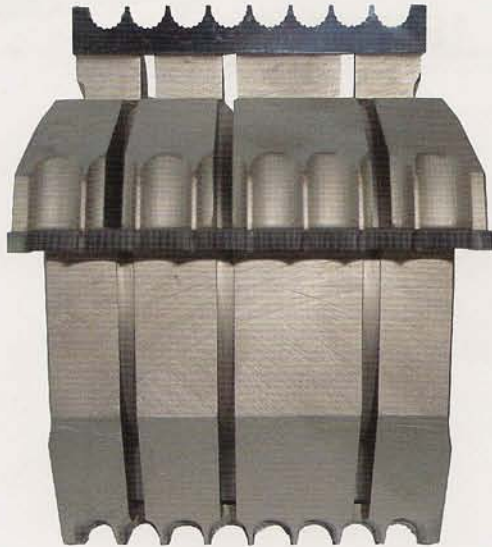

TF503 Round Rod Milling Cutter

Round Rod Milling Cutter

ϕ_{st} mm	ϕD mm	B	ϕd mm	S	T	A	Z
6	110/130	75mm-150mm	30/40	1	7	5	4
7	110/130	75mm-150mm	30/40	1	8	5	4
8	110/130	75mm-150mm	30/40	1	9	5	4
9	110/130	75mm-150mm	30/40	1	10	5	4
10	110/130	75mm-150mm	30/40	1.5	11.5	5	4
11	110/130	75mm-150mm	30/40	1.5	12.5	5	4
12	110/130	75mm-150mm	30/40	1.5	13.5	5	4
13	110/130	75mm-150mm	30/40	1.5	14.5	5	4
14	110/130	75mm-150mm	30/40	1.5	15.5	5	4
15	110/140	75mm-150mm	30/40	1.5	16.5	5	4
16	110/140	75mm-150mm	30/40	1.5	17.5	5	4

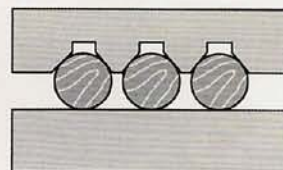
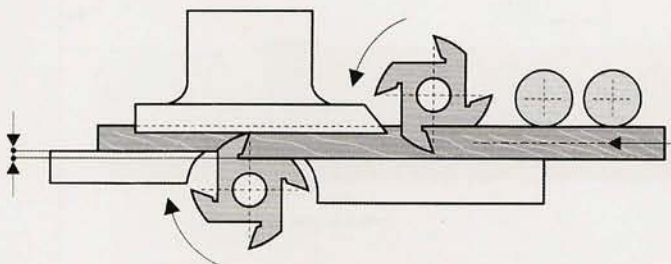



Adjustable Flooring Cutter

(Braze T.C.T=4mm)



• Special specifications is available as per custom's order

TF601A $D125*d40*Z4/Z6$ 1SET/4PCS

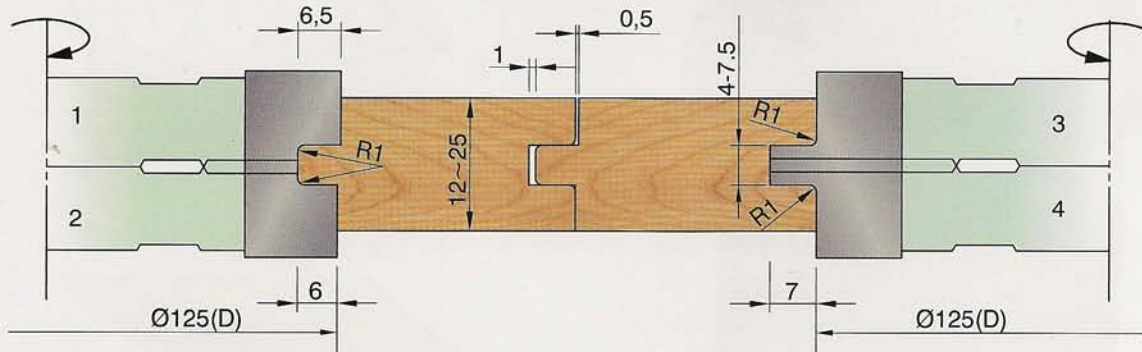

TF601B $D125*d40*Z4/Z6$ 1SET/4PCS

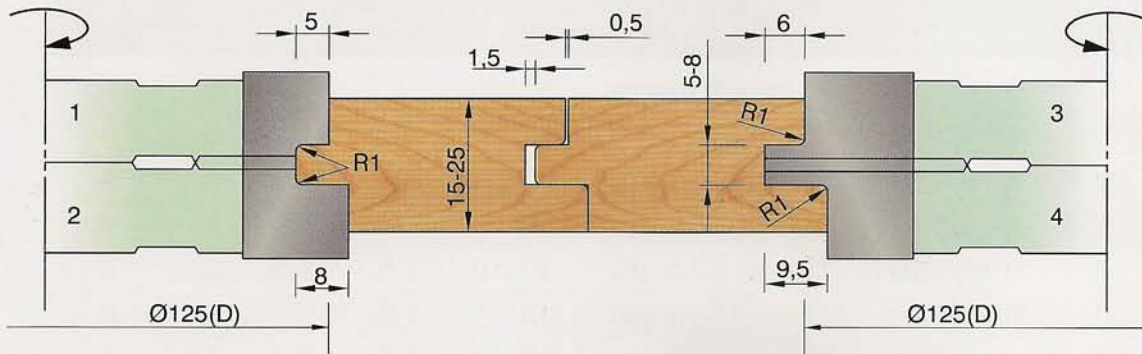

TF601C $D125*d40*Z4/Z6$ 1SET/4PCS

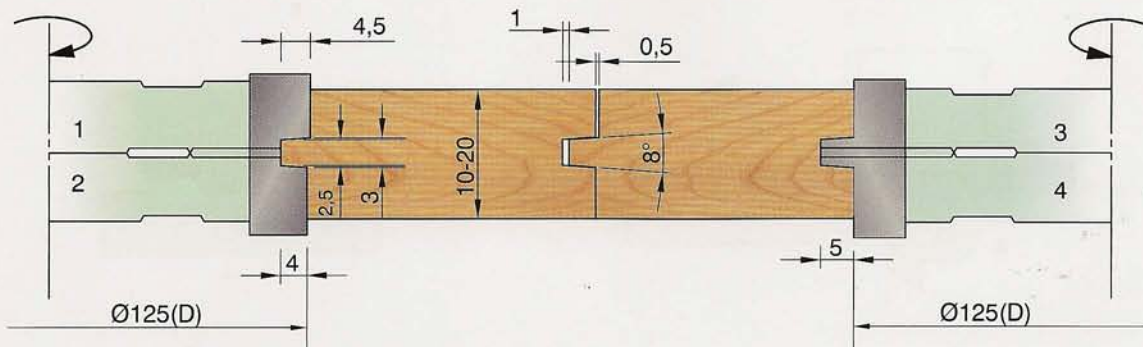

TF601 Adjustable Flooring Cutter



TF601 Adjustable Flooring Cutter

Adjustable Flooring Cutter

(Braze T.C.T=4mm)

• Special specifications is available as per custom's order



TF601D D125*d40*Z4/Z6 1SET/6PCS

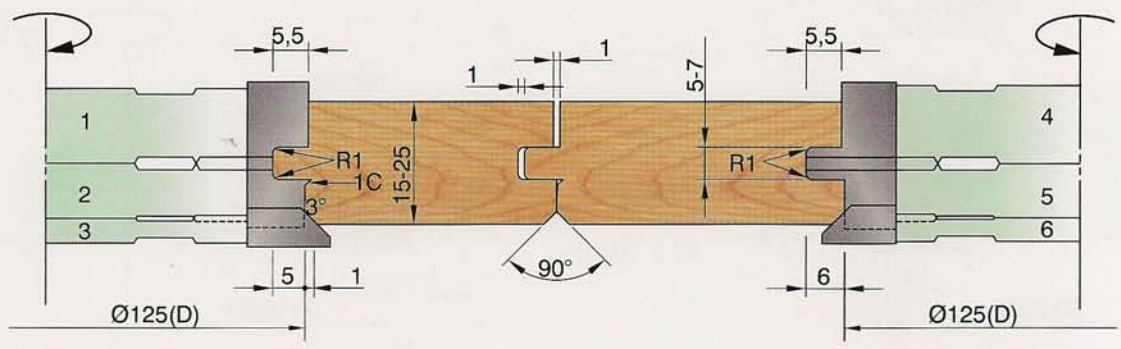

TF601E D125*d40*Z4/Z6 1SET/6PCS

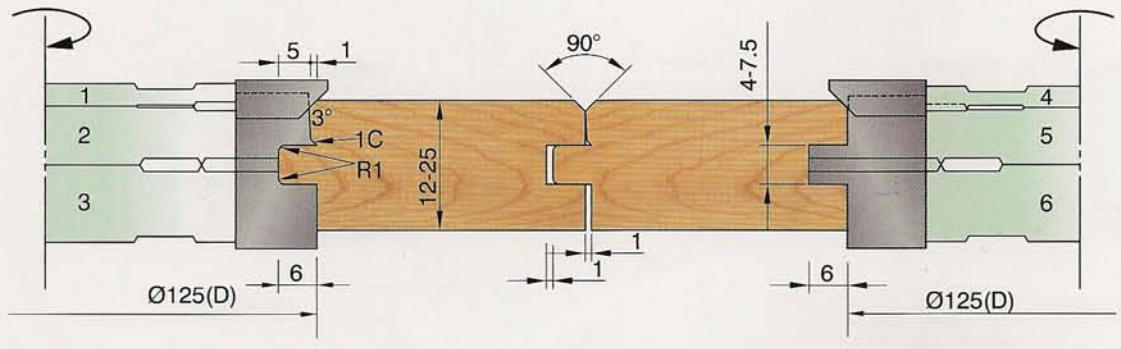

TF601F D125*d40*Z4/Z6 1SET/6PCS

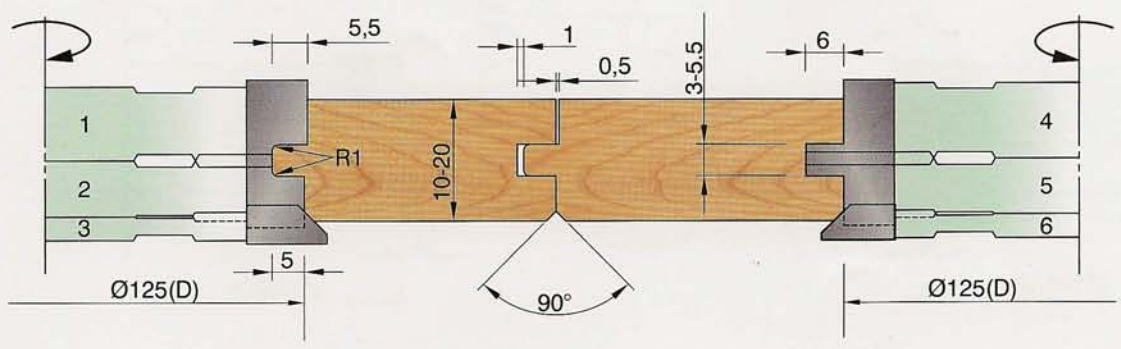



Adjustable Flooring Cutter

(Braze T.C.T=4mm)



• Special specifications is available as per custom's order

TF601G $D125*d40*Z4/Z6$ 1SET/6PCS

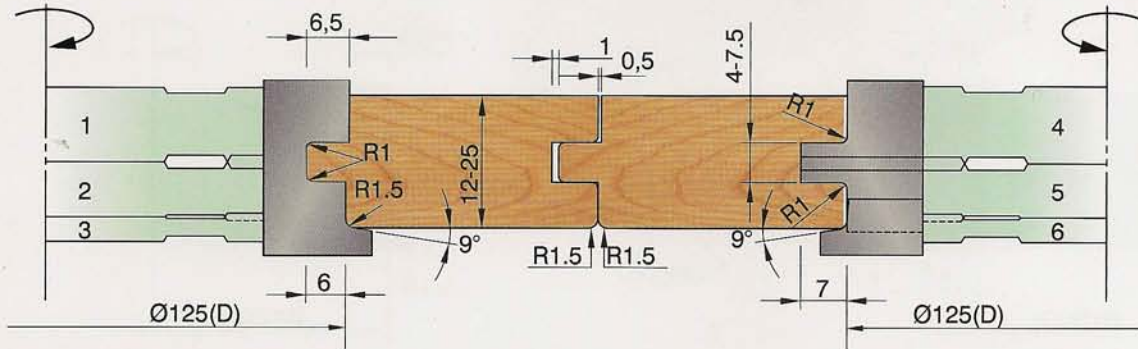

TF601H $D125*d40*Z4/Z6$ 1SET/6PCS

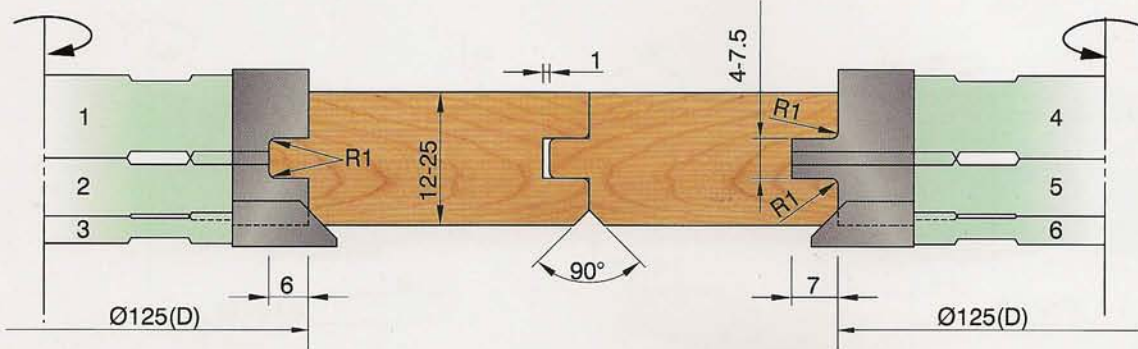

TF601J $D125*d40*Z4/Z6$ 1SET/6PCS

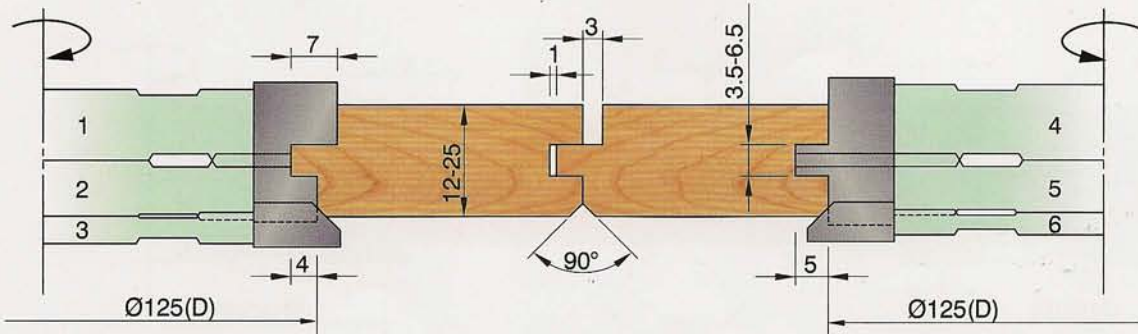

TF601 Adjustable Flooring Cutter



Adjustable Flooring Cutter

(Brazed T.C.T=4mm)

• Special specifications is available as per custom's order



TF601K $D125*d40*Z4/Z6$ 1SET/8PCS

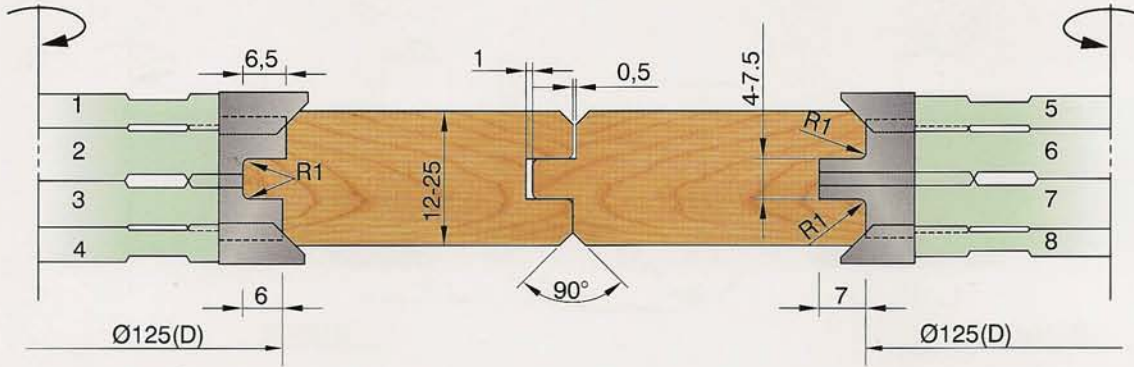

TF601L $D125*d40*Z4/Z6$ 1SET/8PCS

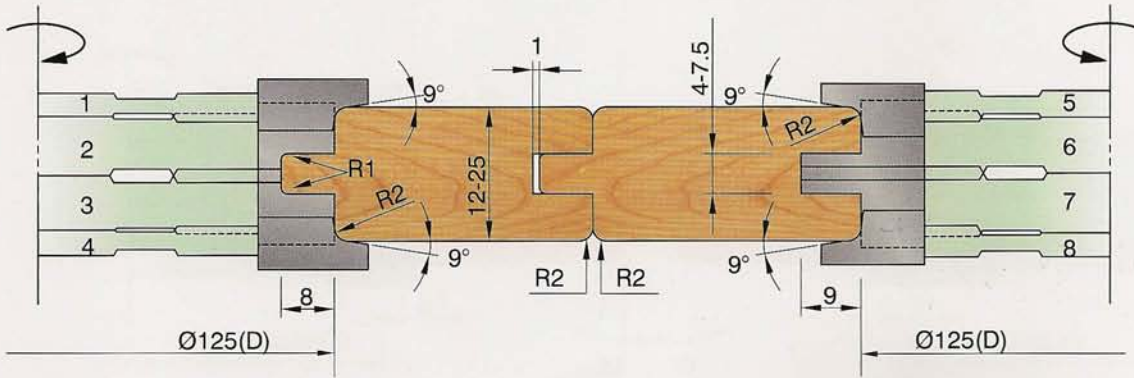

TF601M $D125*d40*Z4/Z6$ 1SET/8PCS

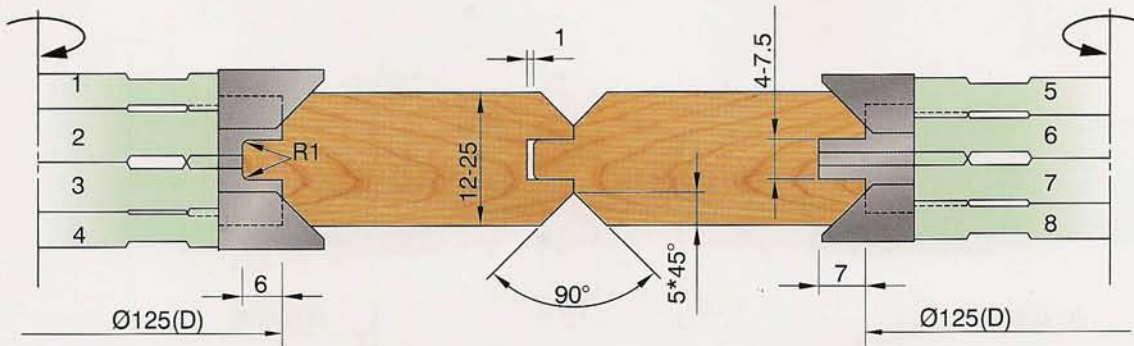



Adjustable Wall Panel Profiling Cutter

(Braze T.C.T=4mm)

• Special specifications is available as per custom's order



TF601N D125*d40*Z4/Z6 1SET/4PCS

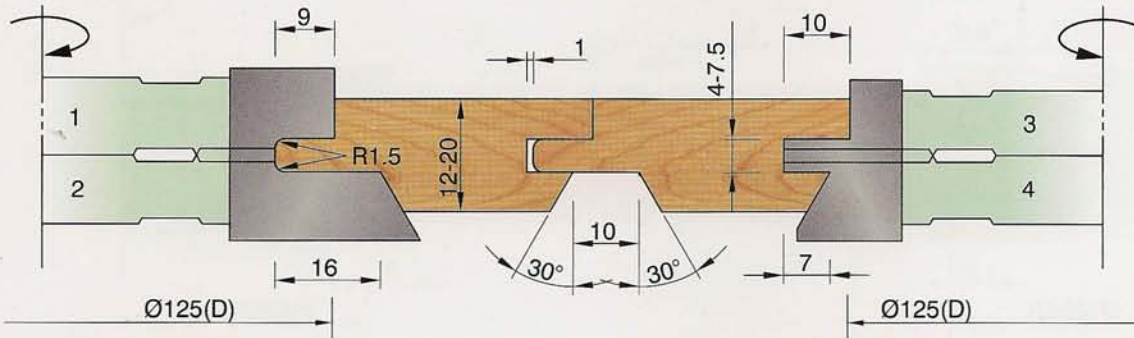

TF601P D125*d40*Z4/Z6 1SET/4PCS

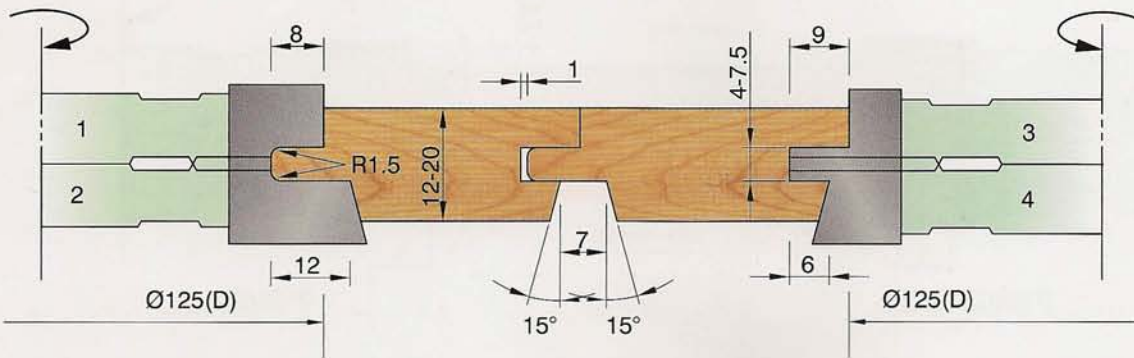

TF601Q D125*d40*Z4/Z6 1SET/4PCS

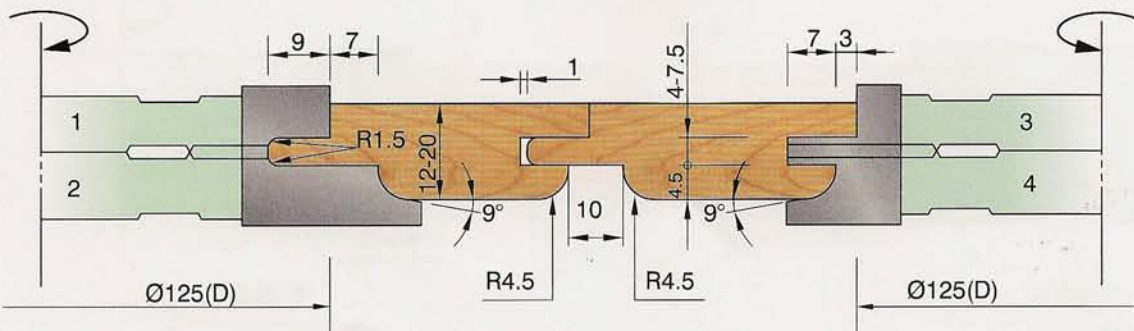

TF601 Adjustable Wall Panel Profiling Cutter



Adjustable Flooring Cutter

(Braze T.C.T=4mm)

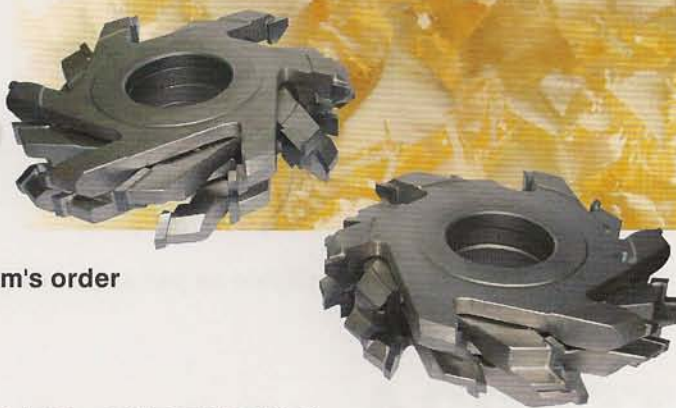

• Special specifications is available as per custom's order

TF601 Adjustable Flooring Cutter

TF601R D140*d40*Z6/Z8 1SET/4PCS

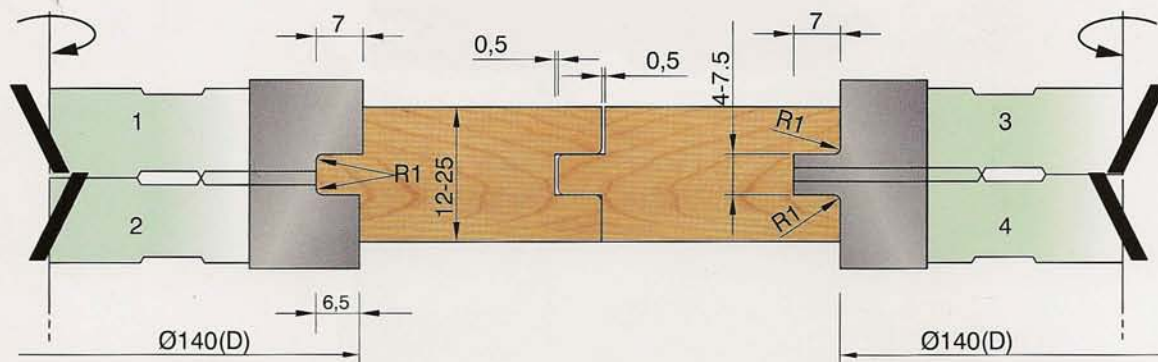

TF601S D140*d40*Z6/Z8 1SET/4PCS

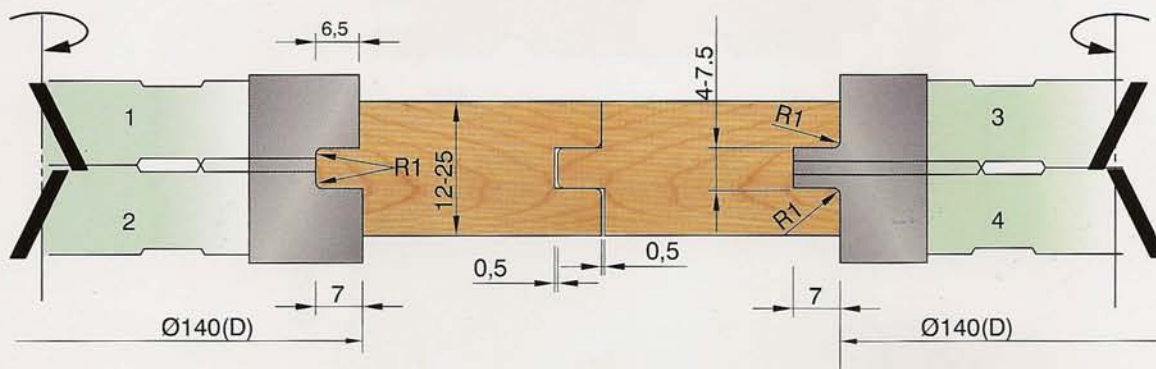

TF601T D140*d40*Z6/Z8 1SET/6PCS

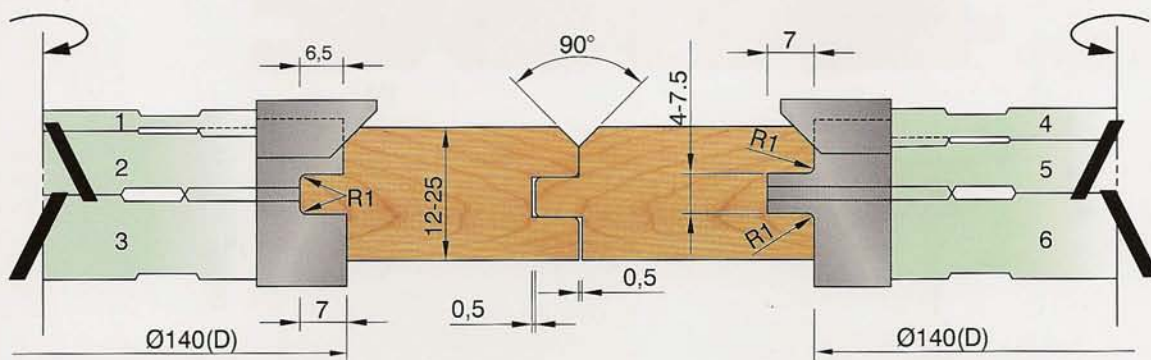



Grooving Cutter For Flooring

(Brazed T.C.T=4mm)

• Special specifications is available as per custom's order



TF602A D125*d40*Z4

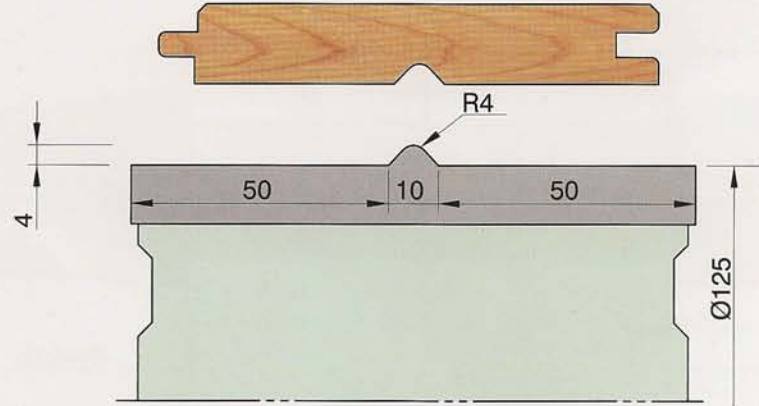

TF602B D125*d40*Z4

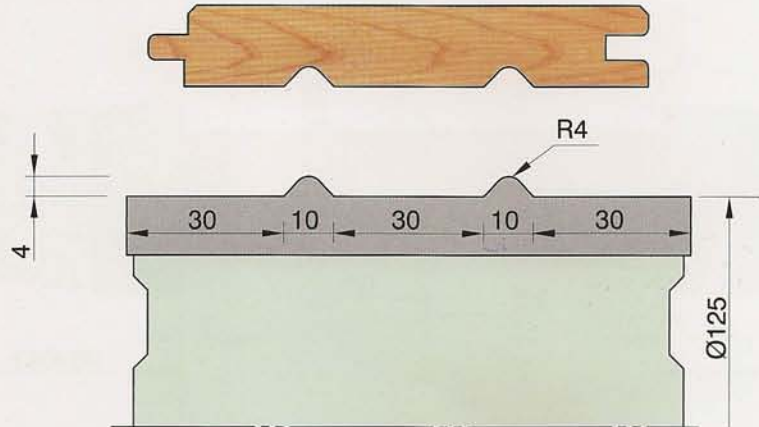

TF602C D125*d40*Z4

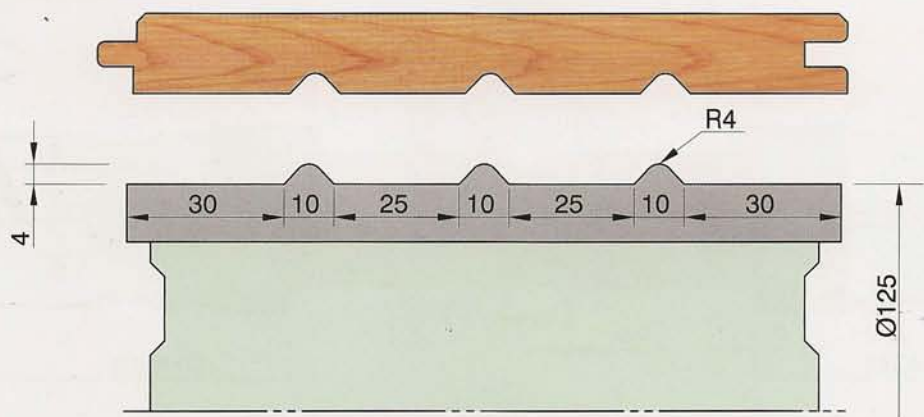

TF602 Grooving Cutter For Flooring



Grooving Cutter For Flooring

(Brazed T.C.T=4mm)

• Special specifications is available as per custom's order



TF602 Grooving Cutter For Flooring

TF602D D125*d40*Z4

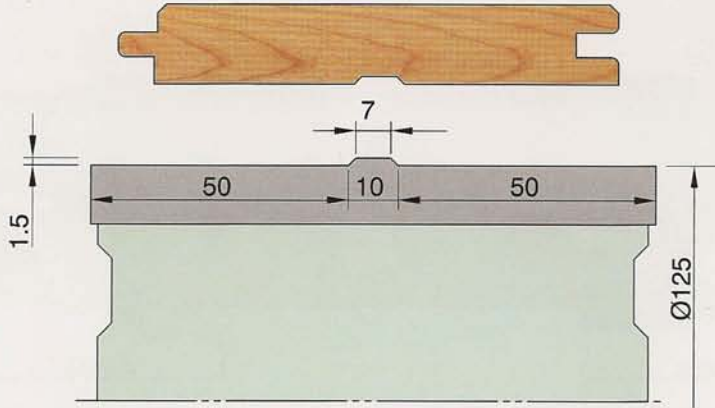

TF602E D125*d40*Z4

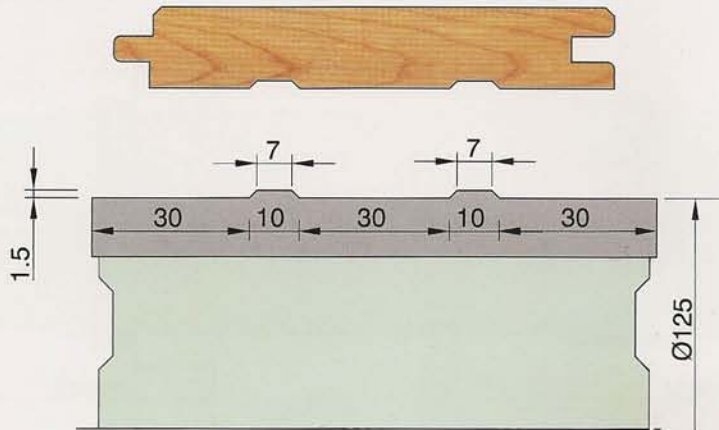

TF602F D125*d40*Z4

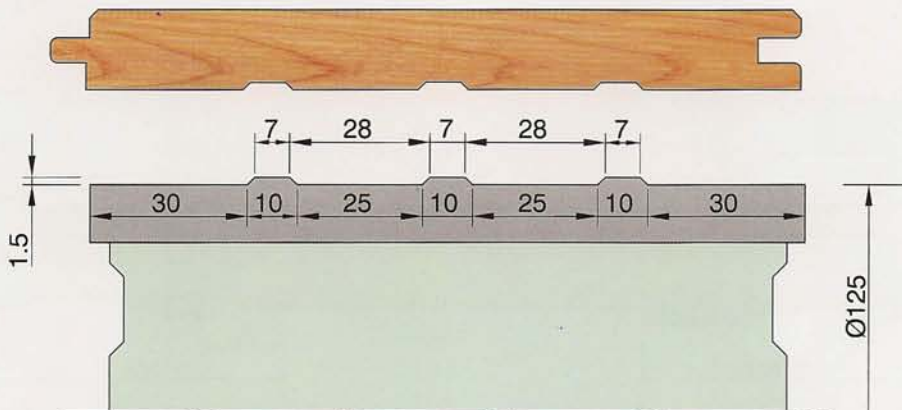



Adjustable Profile Cutter for Door

(Braze T.C.T=4mm)



- Special specifications is available as per custom's order.

TF603A D140*d40*Z4 1SET/6PCS

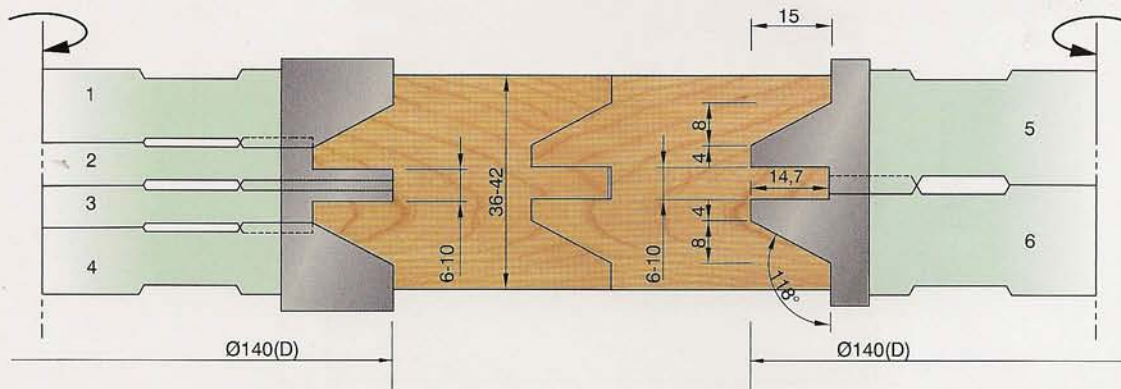

TF603B D140*d40*Z4 1SET/6PCS

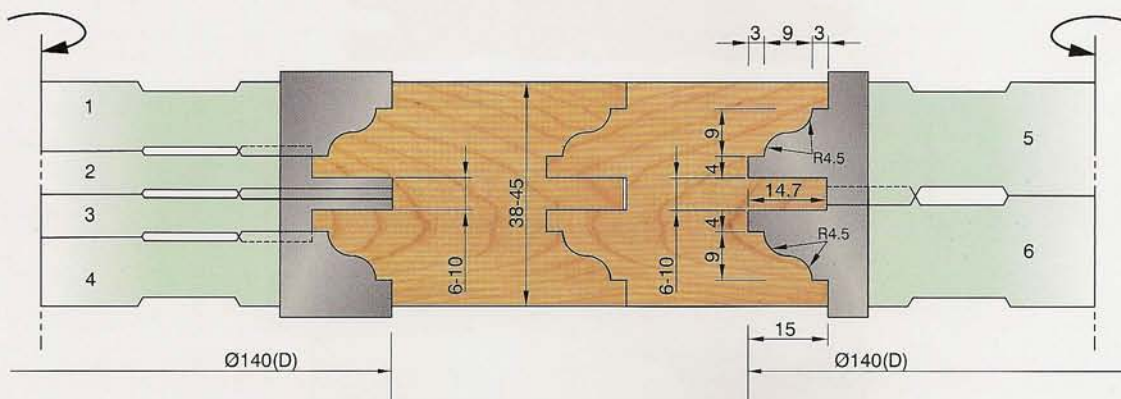

TF603C D140*d40*Z4 1SET/6PCS

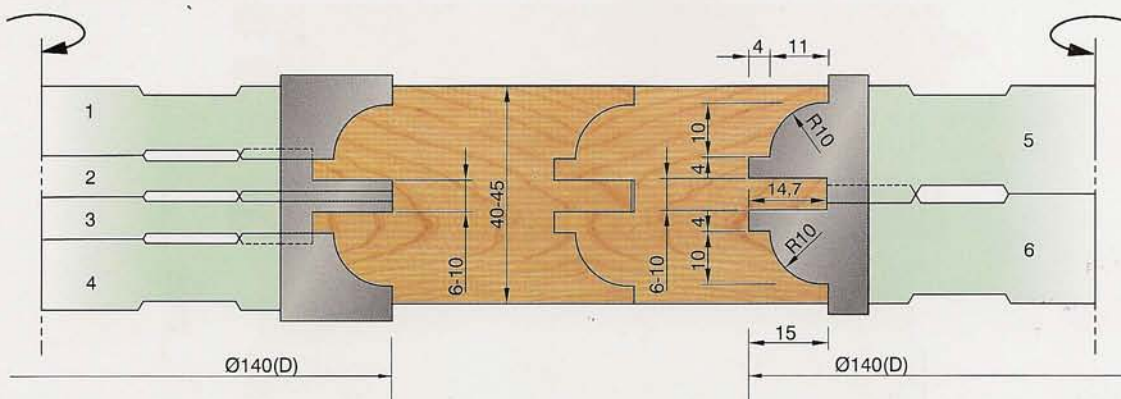



Adjustable Profile Cutter for Door

(Braze T.C.T=4mm)

• Special specifications is available as per custom's order



TF603D D140*d40*Z4 1SET/6PCS

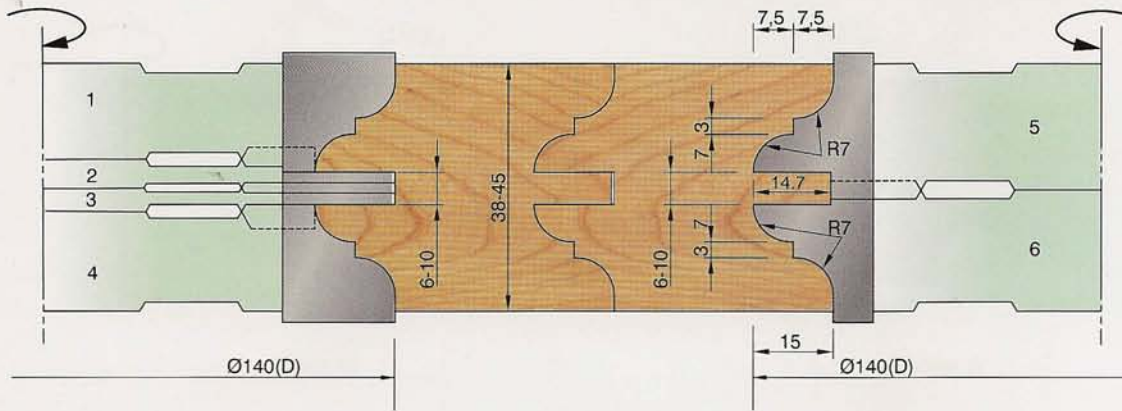

TF603E D140*d40*Z4 1SET/6PCS

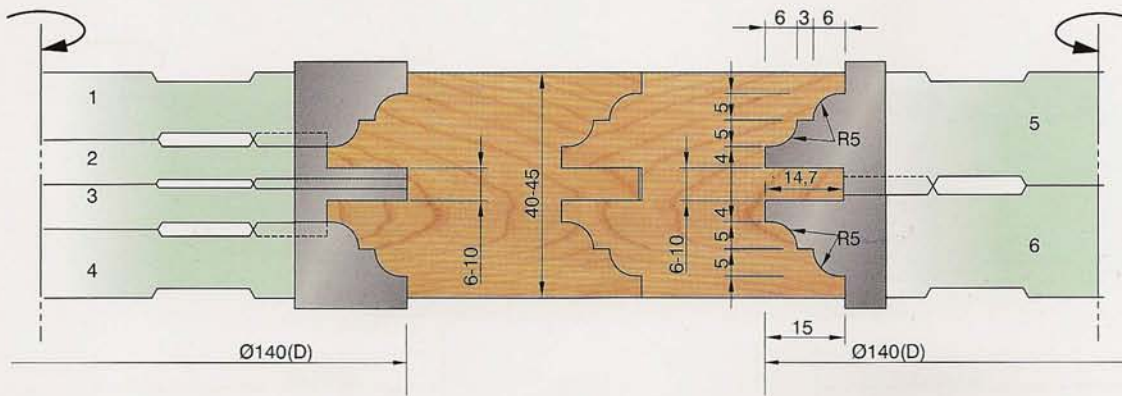

TF603F D140*d40*Z4 1SET/6PCS

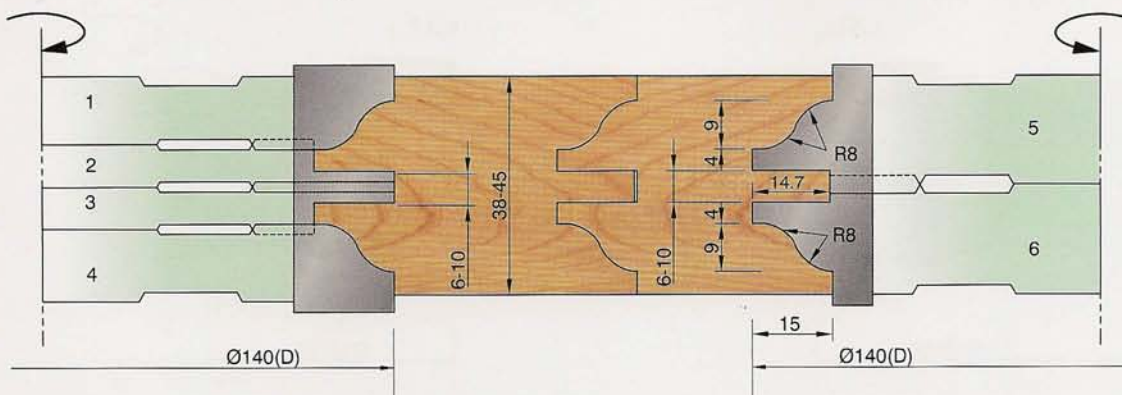

TF603 Adjustable Profile Cutter for Door



Adjustable Profile Cutter for Cabinet Door Frame

(Braze T.C.T=4mm)

• Special specifications is available as per custom's order.

TF605A D125*d35*Z4 1SET/5PCS

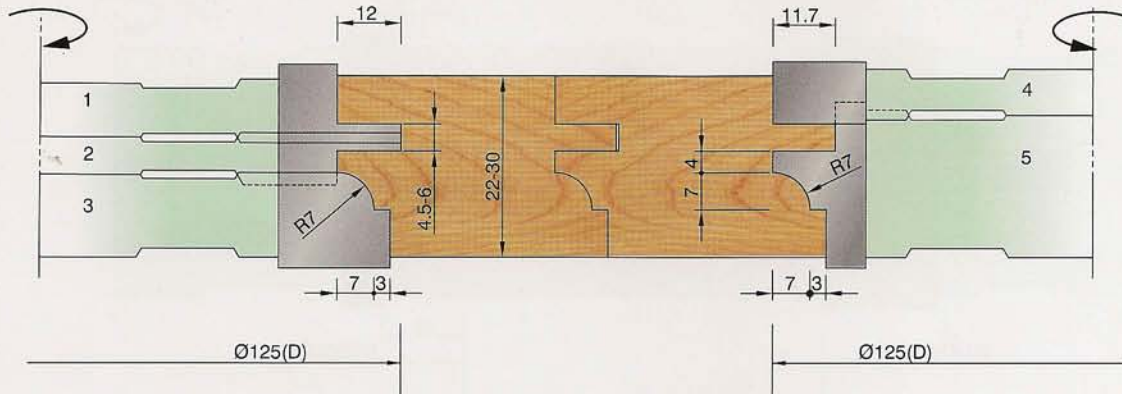

TF605B D125*d35*Z4 1SET/5PCS

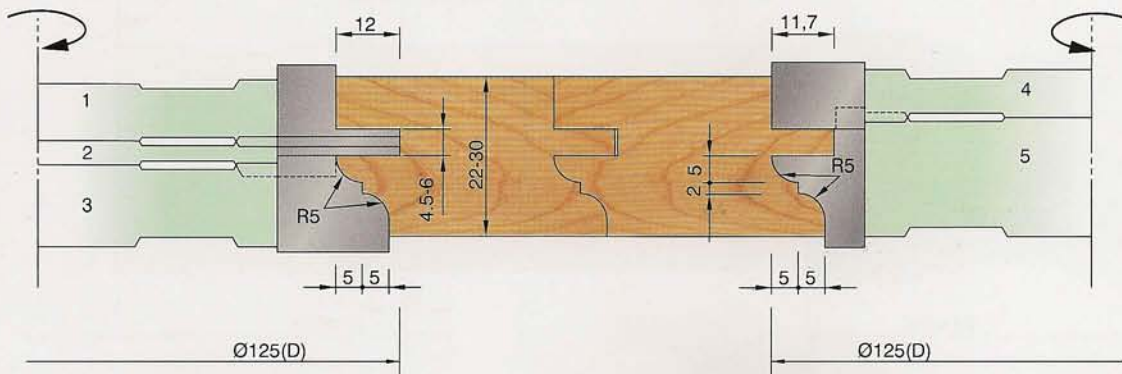

TF605C D125*d35*Z4 1SET/5PCS

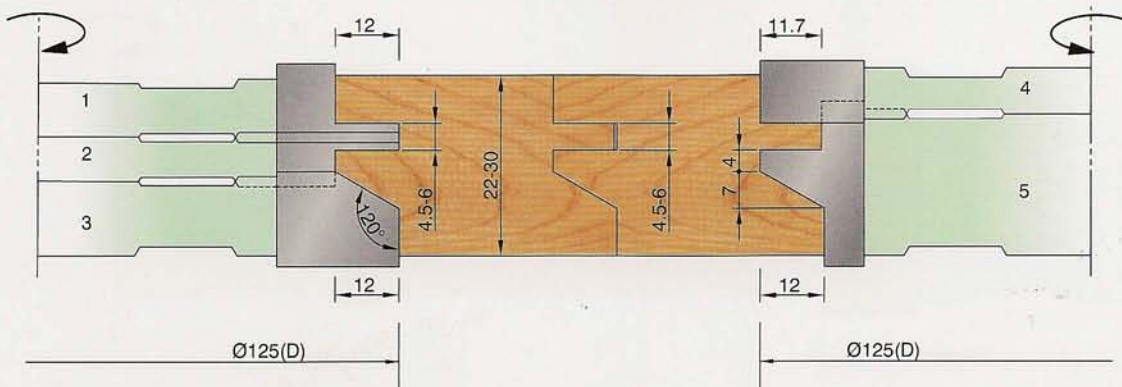

TF605 Adjustable Profile Cutter for Cabinet Door Frame

Adjustable Profile Cutter for Cabinet Door Frame

(Brazed T.C.T=4mm)

- Special specifications is available as per custom's order.

TF605D D125*d35*Z4 1SET/5PCS

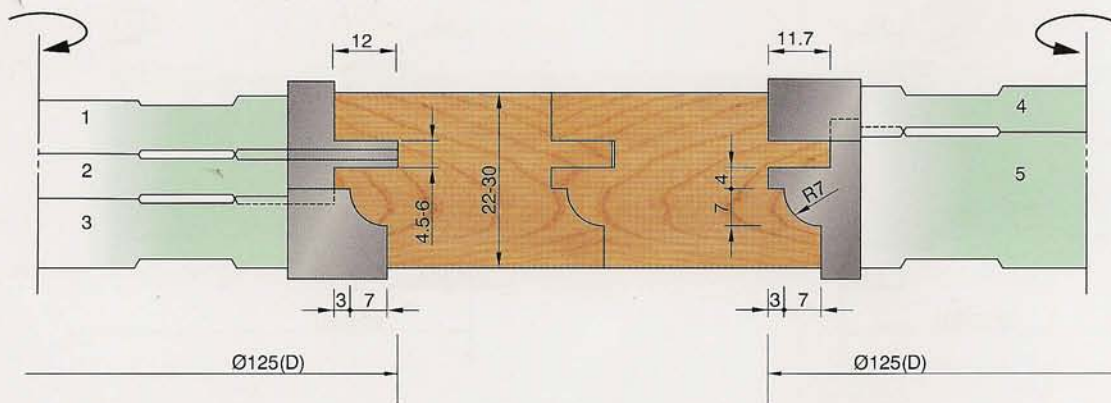

TF605E D130*d35*Z4 1SET/5PCS

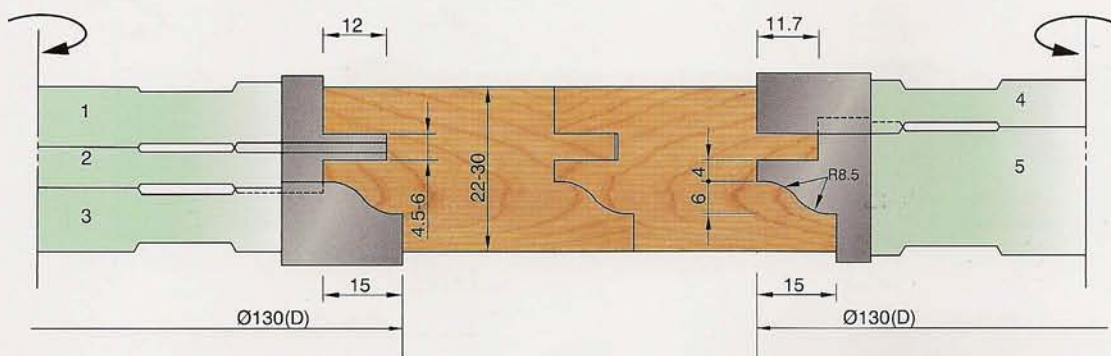

TF605F D125*d35*Z4 1SET/5PCS

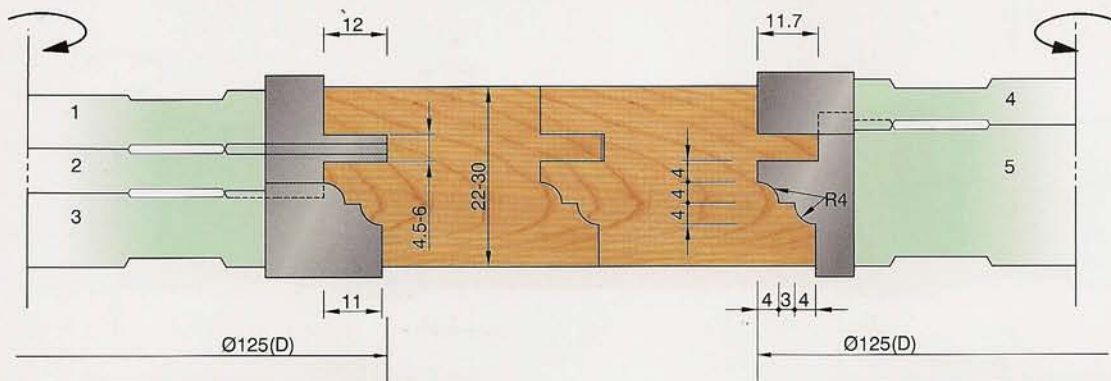

TF605 Adjustable Profile Cutter for Cabinet Door Frame



Adjustable Profile Cutter for Cabinet Glass Door Frame

(Braze T.C.T=4mm)

• Special specifications is available as per custom's order.

TF606A D125*d30*Z4 1SET/4PCS

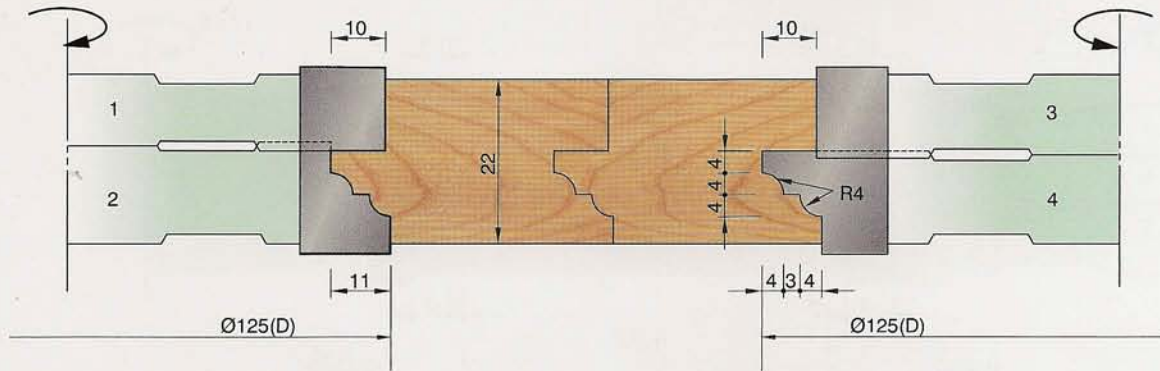

TF606B D125*d30*Z4 1SET/4PCS

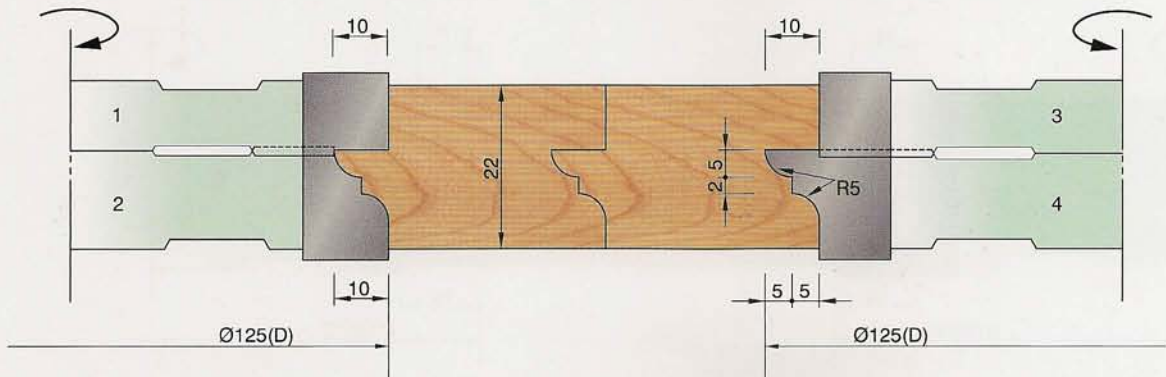

TF606C D125*d30*Z4 1SET/4PCS

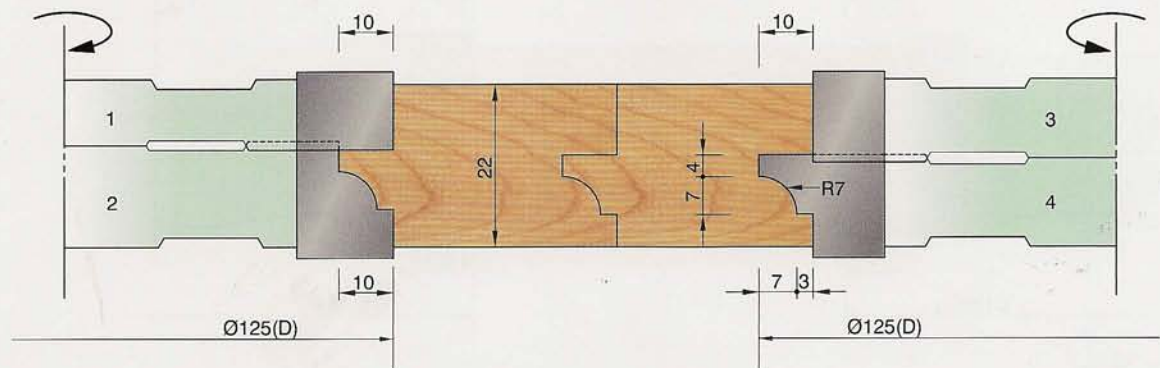

TF606 Adjustable Profile Cutter for Cabinet Glass Door Frame

Adjustable Profile Cutter for Cabinet Glass Door Frame

(Braze T.C.T=4mm)

- Special specifications is available as per custom's order.

TF606D D140*d35*Z4 1SET/4PCS

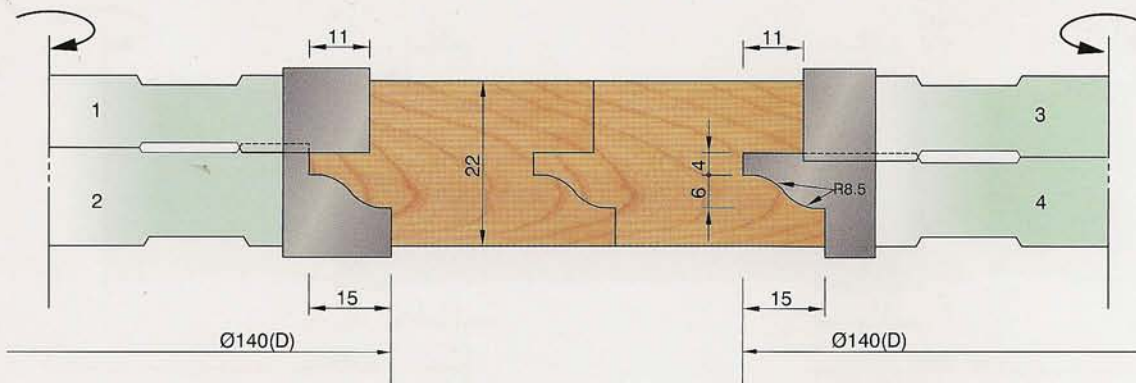

TF606E D125*d35*Z4 1SET/4PCS

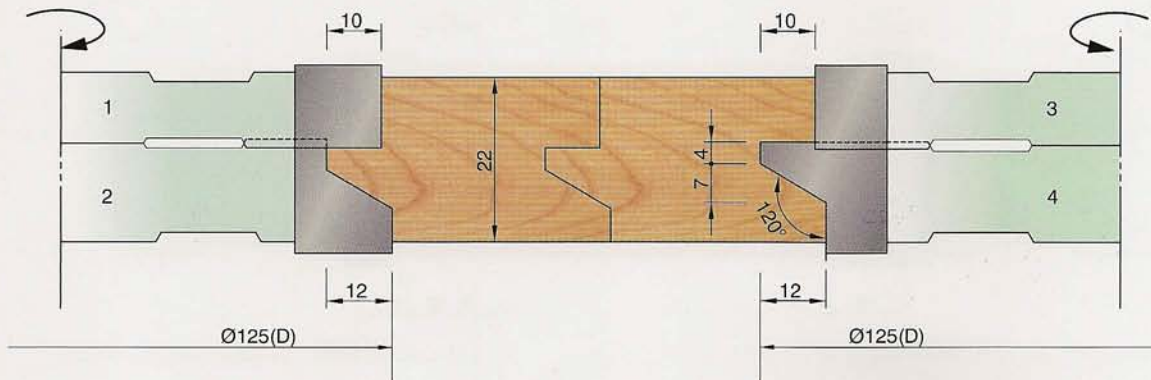

TF606F D125*d35*Z4 1SET/4PCS

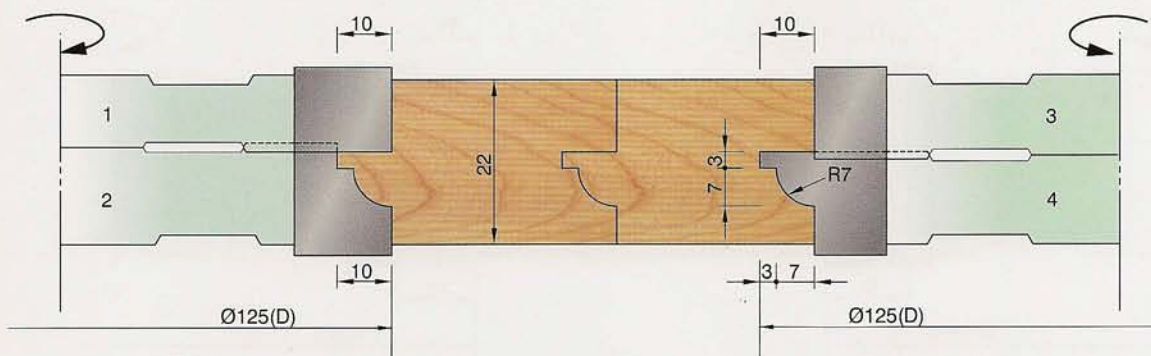



Adjustable Profile Cutter for Cabinet Glass Door Frame

(Braze T.C.T=4mm)

• Special specifications is available as per custom's order.

TF607A D140*d30*Z4 1SET/4PCS

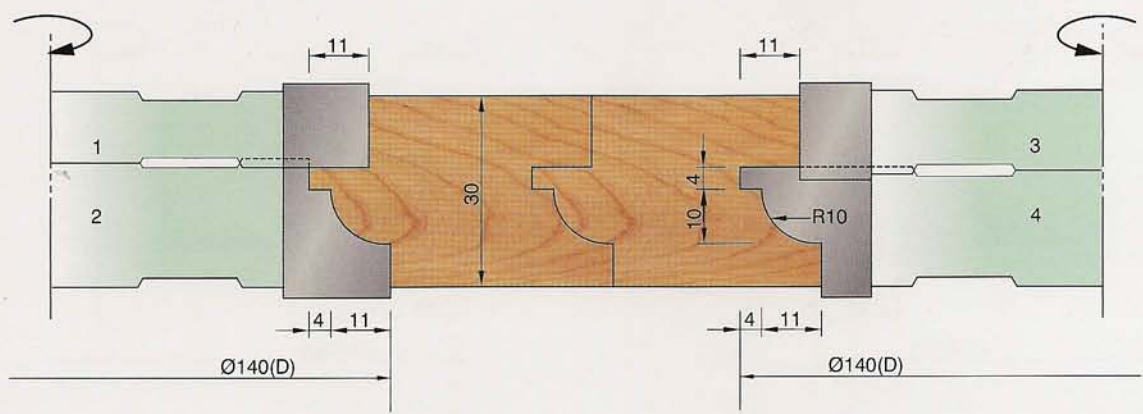

TF607B D140*d30*Z4 1SET/4PCS

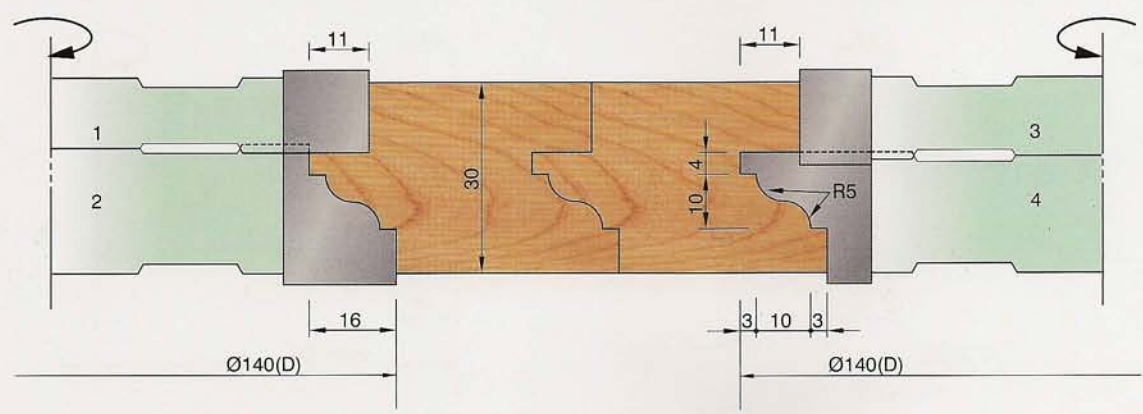

TF607C D140*d30*Z4 1SET/4PCS

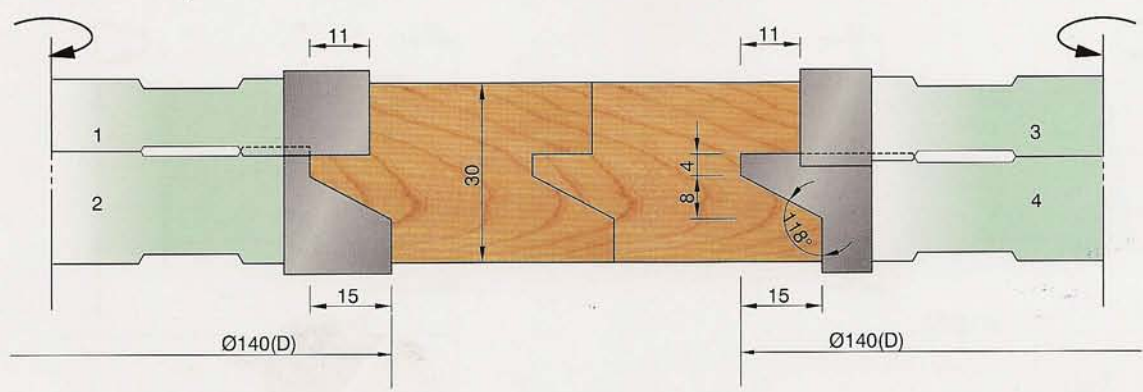

TF607 Adjustable Profile Cutter for Cabinet Glass Door Frame



Adjustable Profile Cutter for Cabinet Glass Door Frame

(Braze T.C.T=4mm)

• Special specifications is available as per custom's order.

TF607 Adjustable Profile Cutter for Cabinet Glass Door Frame

TF607D D140*d35*Z4 1SET/4PCS

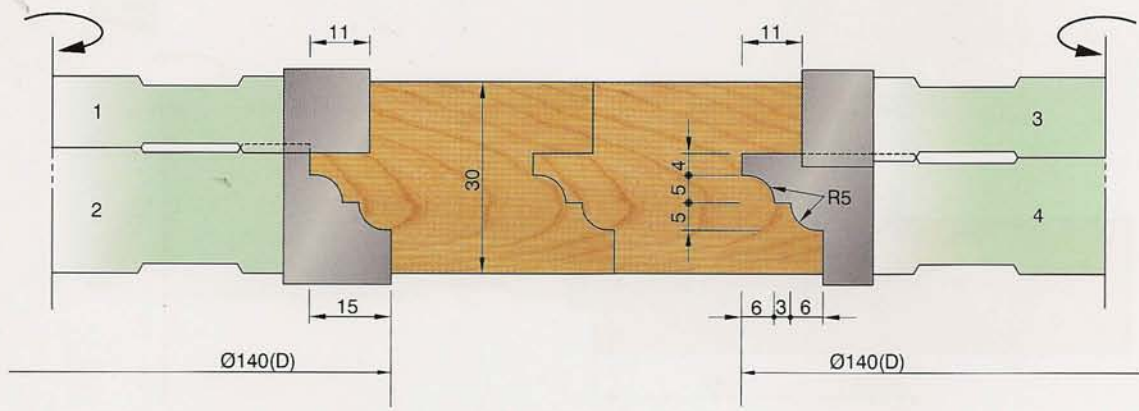

TF607E D140*d35*Z4 1SET/4PCS

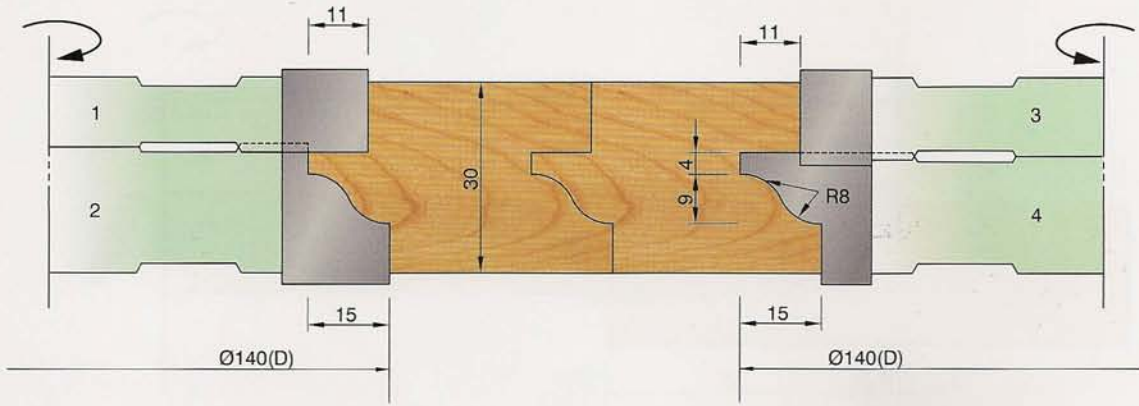

TF607F D140*d35*Z4 1SET/4PCS

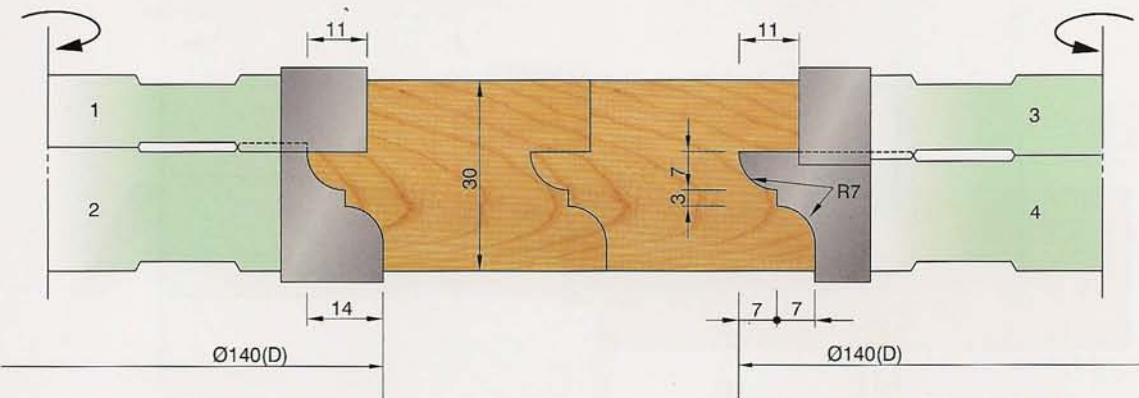



Profile Cutter for Door Panel

(Braze T.C.T=4mm)



• Special specifications is available as per custom's order.

TF608 Profile Cutter for Door Panel

TF608A D180*d30*Z4/Z6

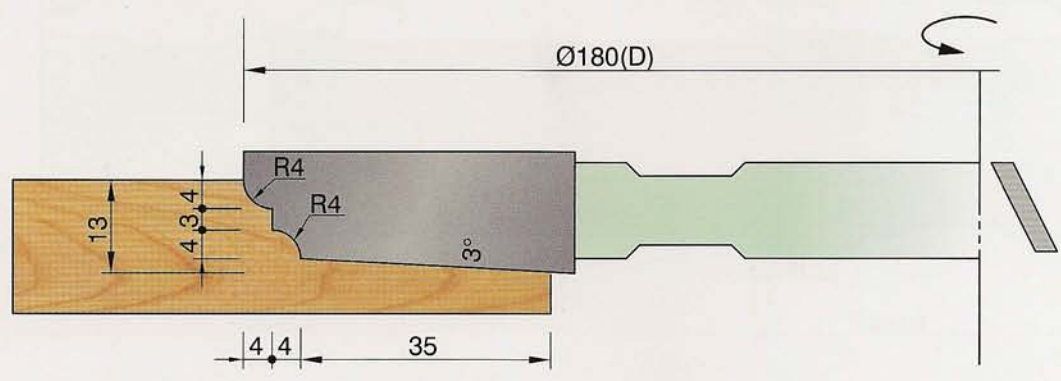

TF608B D180*d30*Z4/Z6

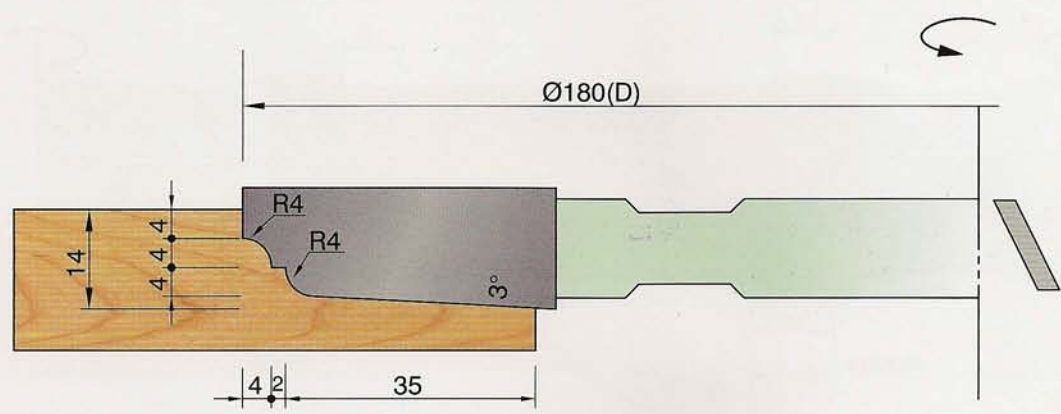

TF608C D180*d30*Z4/Z6

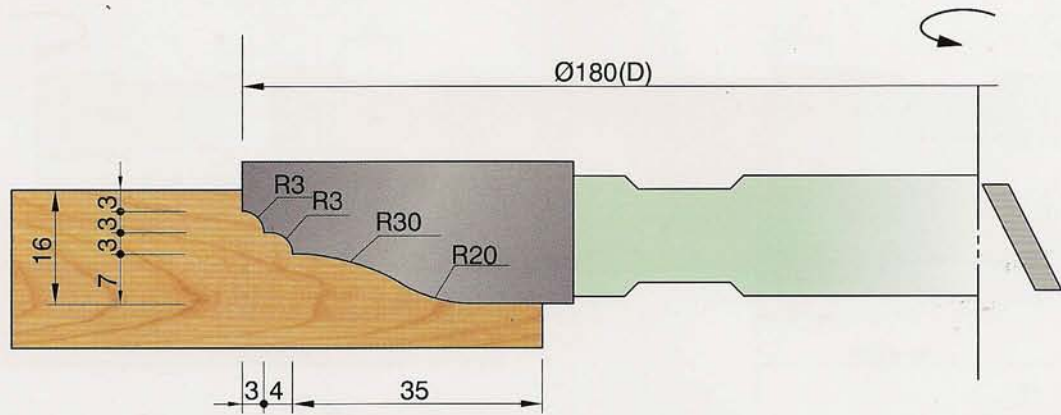

Profile Cutter for Door Panel

(Braze T.C.T=4mm)

• Special specifications is available as per custom's order.



TF608D $D180*d30*Z4/Z6$

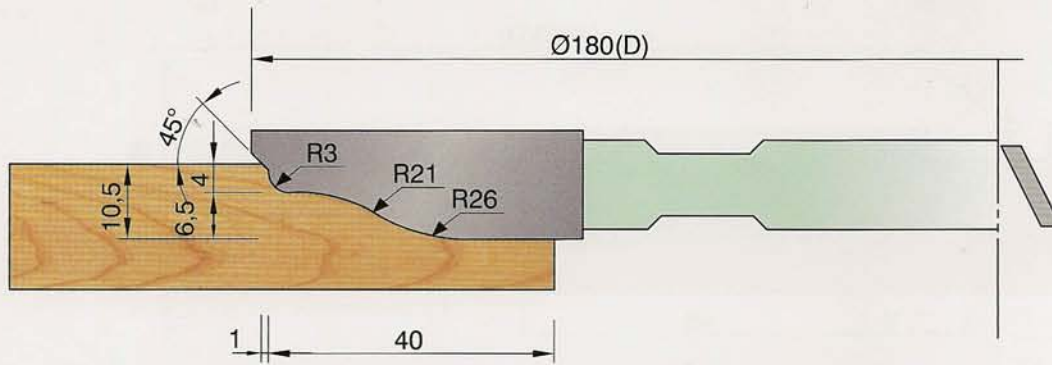

TF608E $D180*d30*Z4/Z6$

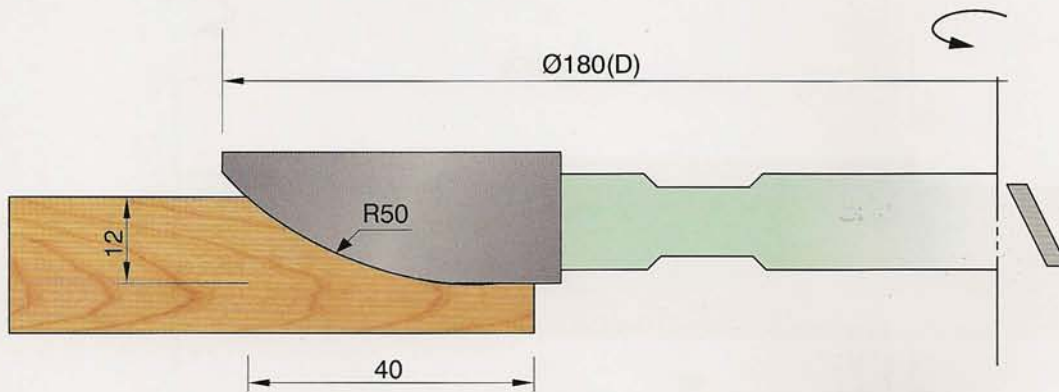

TF608F $D180*d30*Z4/Z6$

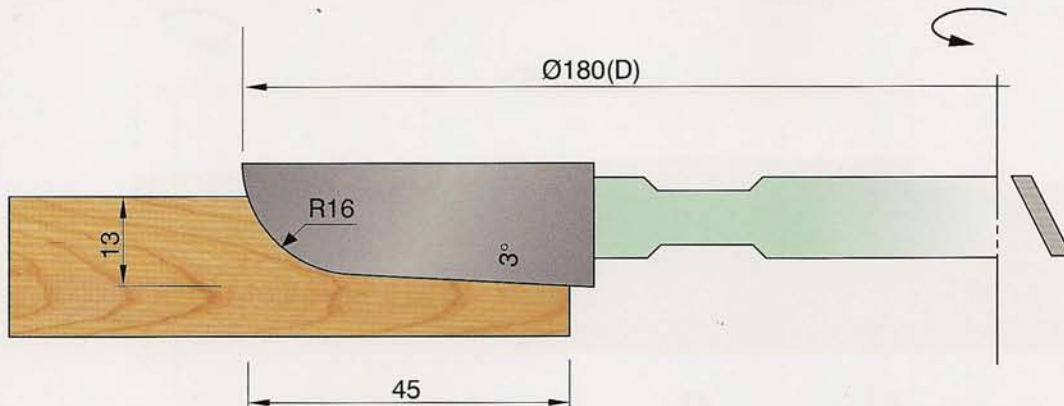



Profile Cutter for Door Panel

(Braze T.C.T=4mm)



- Special specifications is available as per custom's order.

TF608G $D200*d30*Z4/Z6$

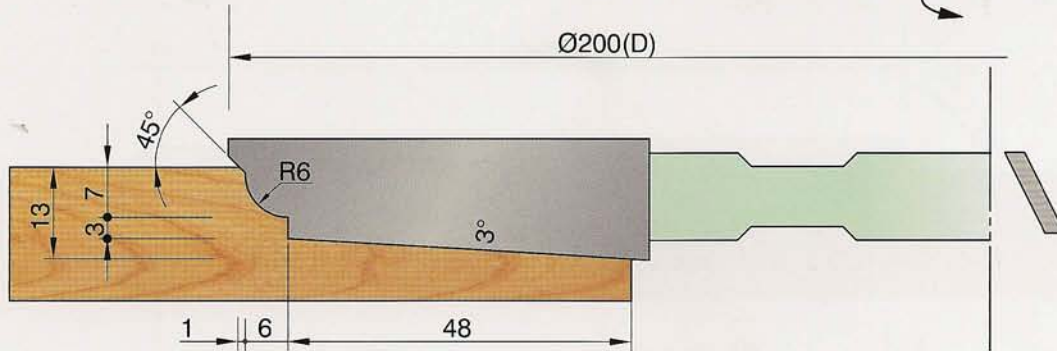

TF608H $D200*d30*Z4/Z6$

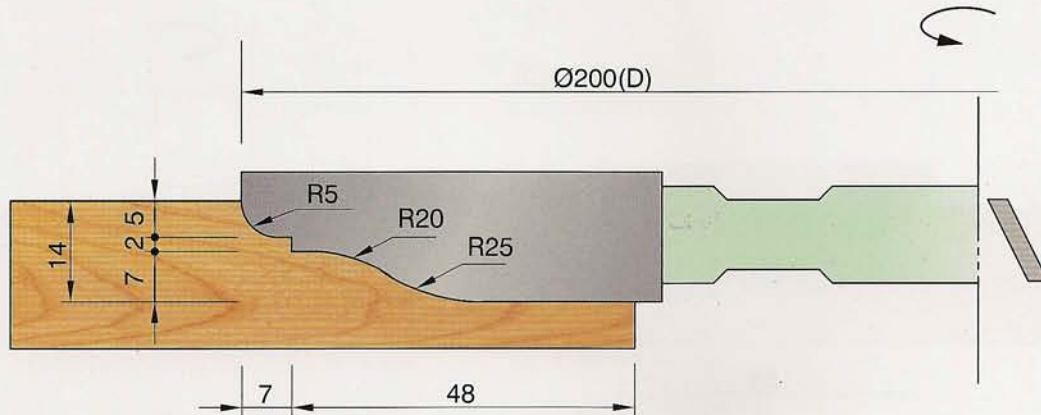

TF608J $D200*d30*Z4/Z6$

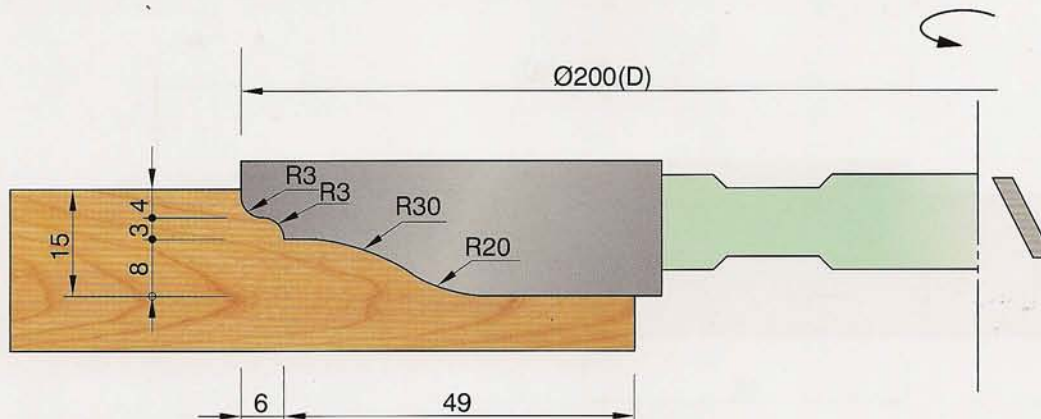

TF608 Profile Cutter for Door Panel

Profile Cutter for Door Panel

(Brazed T.C.T=4mm)

• Special specifications is available as per custom's order.



TF608K D180*d30*Z4/Z6

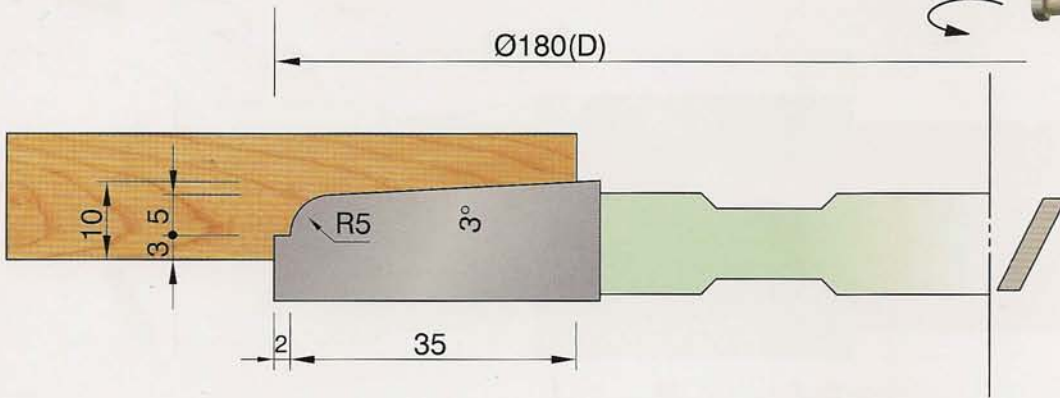

TF608L D180*d30*Z4/Z6

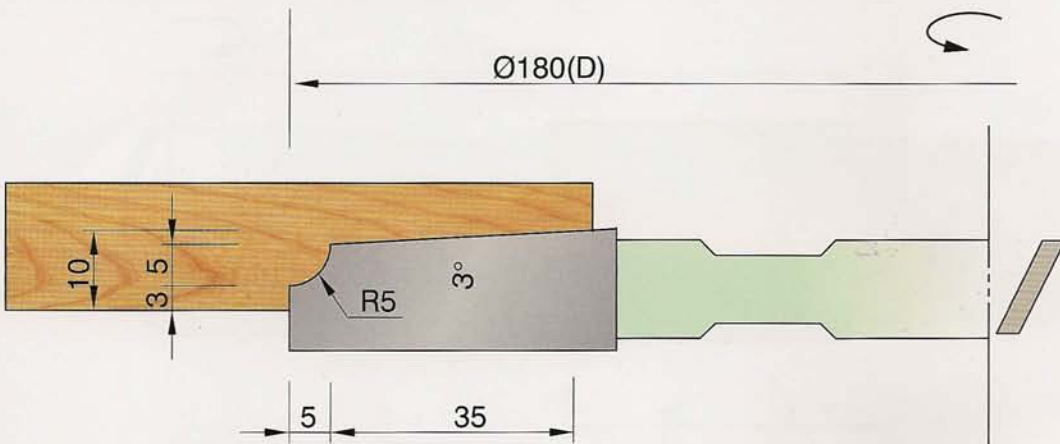

TF608M D180*d30*Z4/Z6

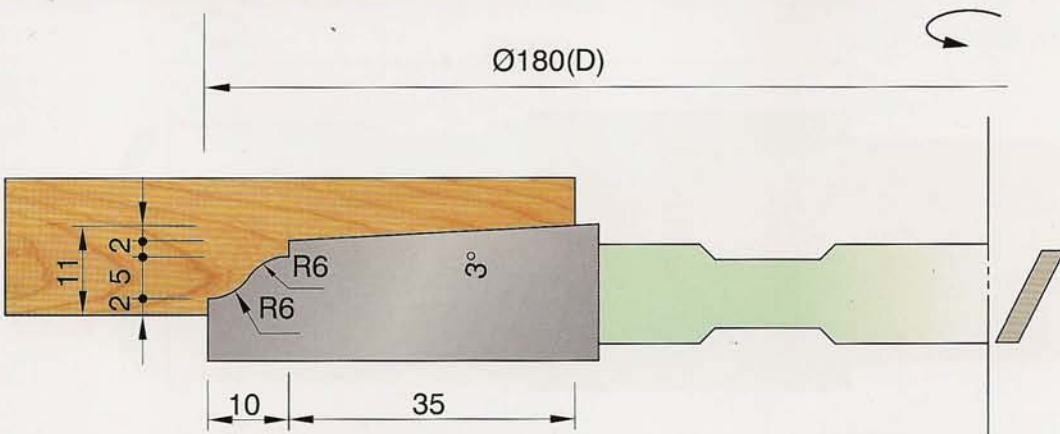



Adjustable Profile Cutter for Door Panel

(Braze T.C.T=4mm)

• Special specifications is available as per custom's order.



TF609A D180*d30*Z4/Z6 1SET/2PCS

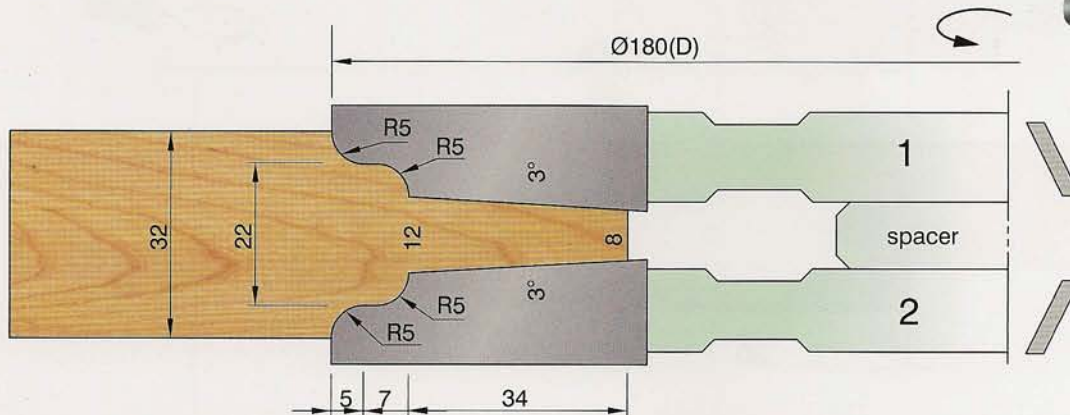

TF609B D180*d30*Z4/Z6 1SET/2PCS

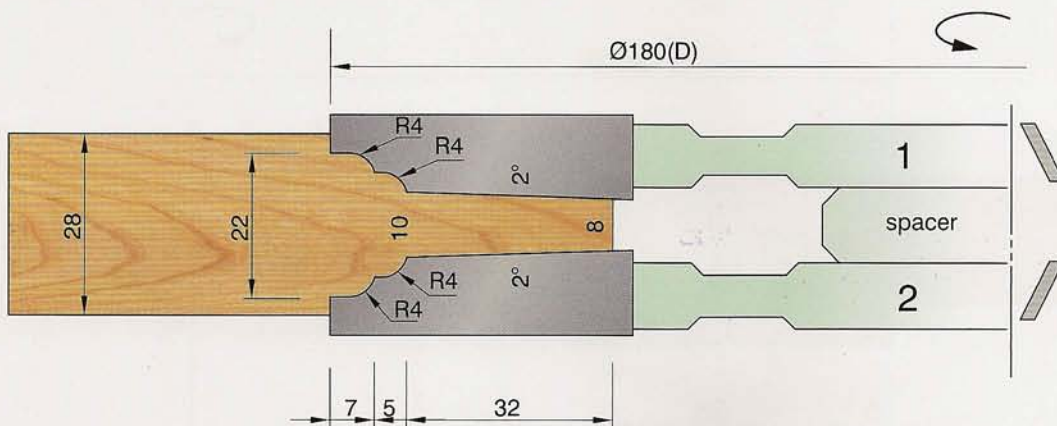

TF609C D180*d30*Z4/Z6 1SET/2PCS

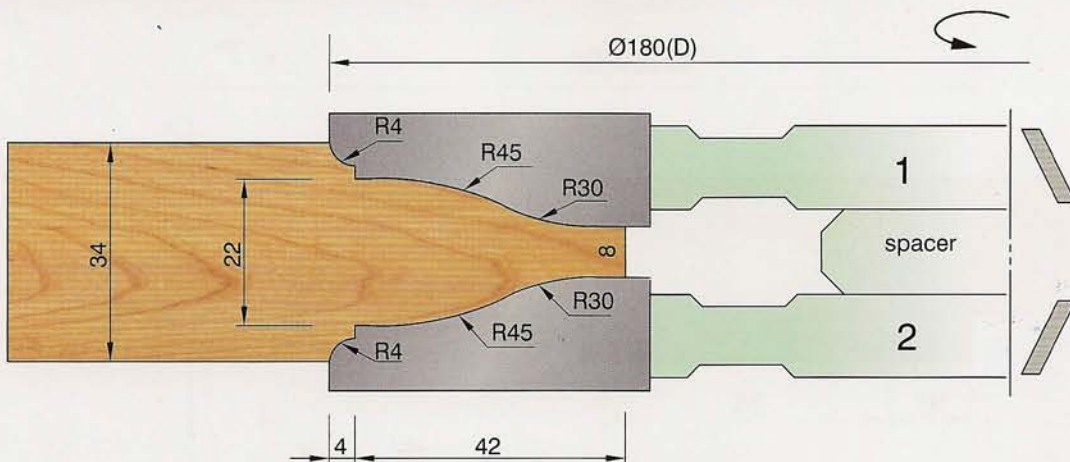

TF609 Adjustable Profile Cutter for Door Panel



TF609 Adjustable Profile Cutter for Door Panel

Adjustable Profile Cutter for Door Panel

(Braze T.C.T=4mm)

• Special specifications is available as per custom's order.



TF609D D180*d30*Z4/Z6 1SET/2PCS

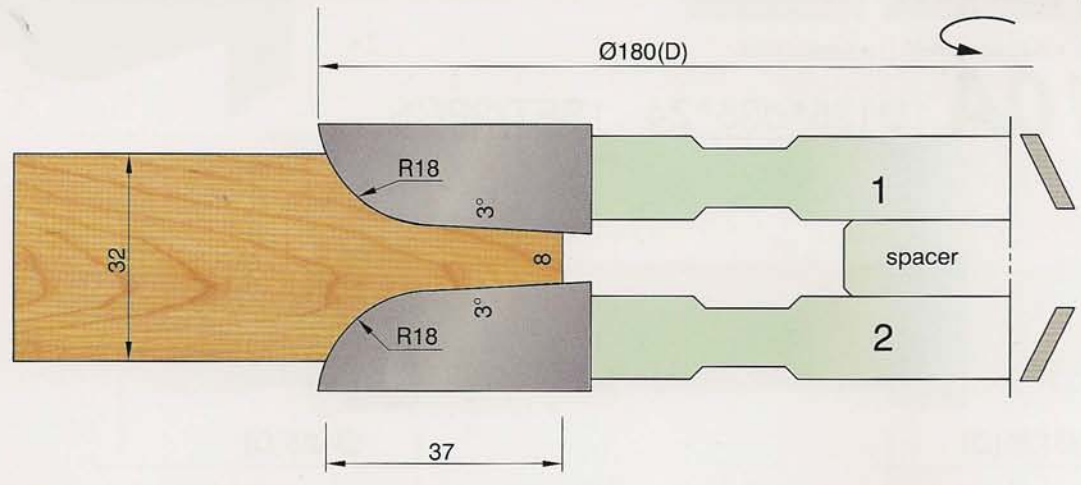

TF609E D180*d30*Z4/Z6 1SET/2PCS

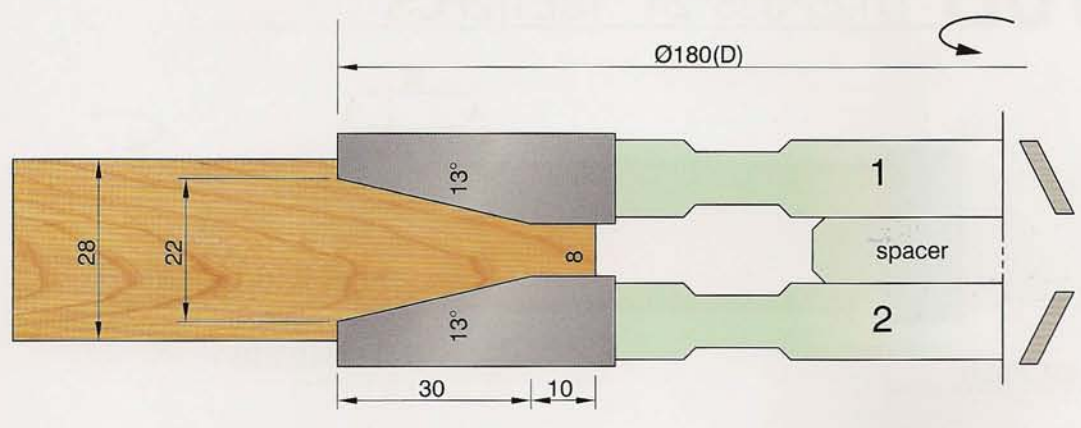

TF609F D180*d30*Z4/Z6 1SET/2PCS

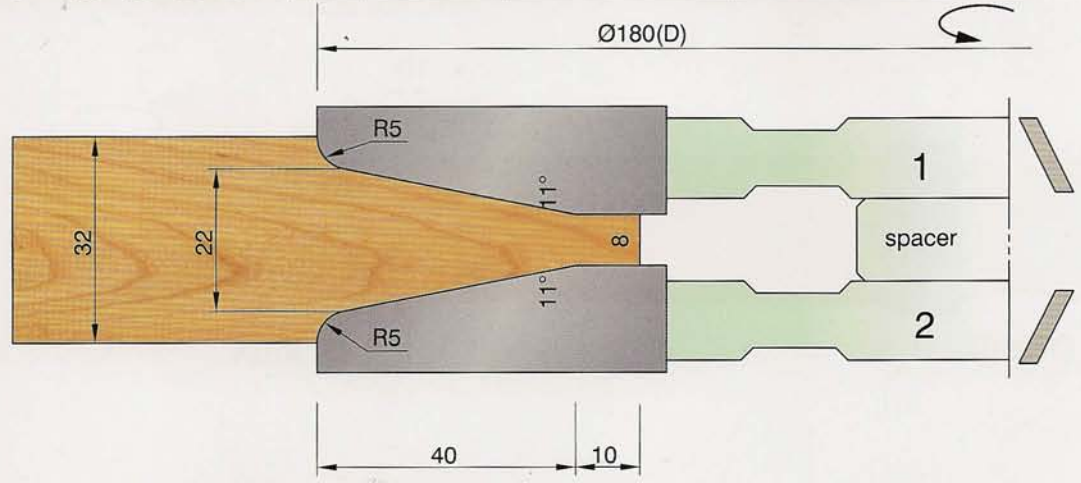



TF610 Fixed Finger Jointer Cutter

Fixed Finger Jointer Cutter

(Braze T.C.T=3mm)

• Special specifications is available as per custom's order

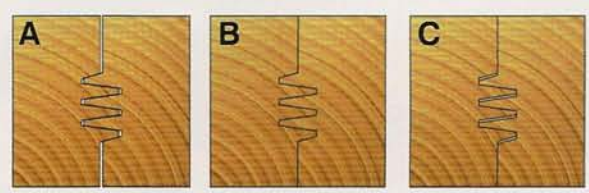

• Tight joint • Regular joint • Loose joint

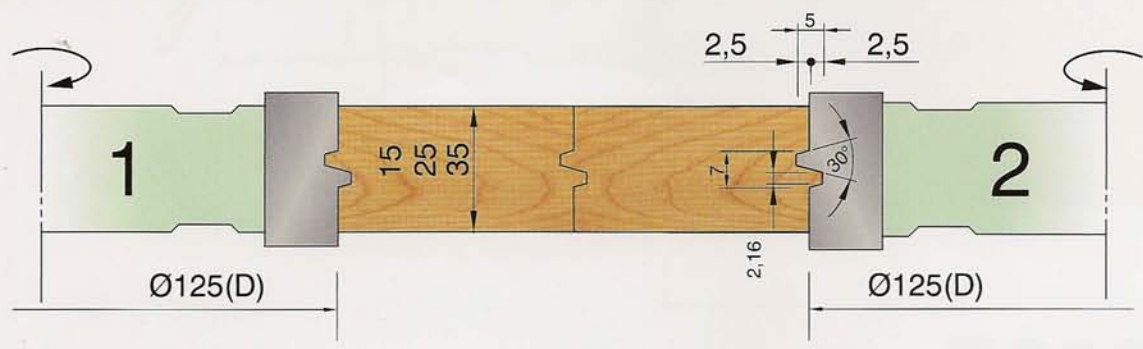

TF610A

 $D125*d35*Z4$ 1SET/2PCS

TF610B

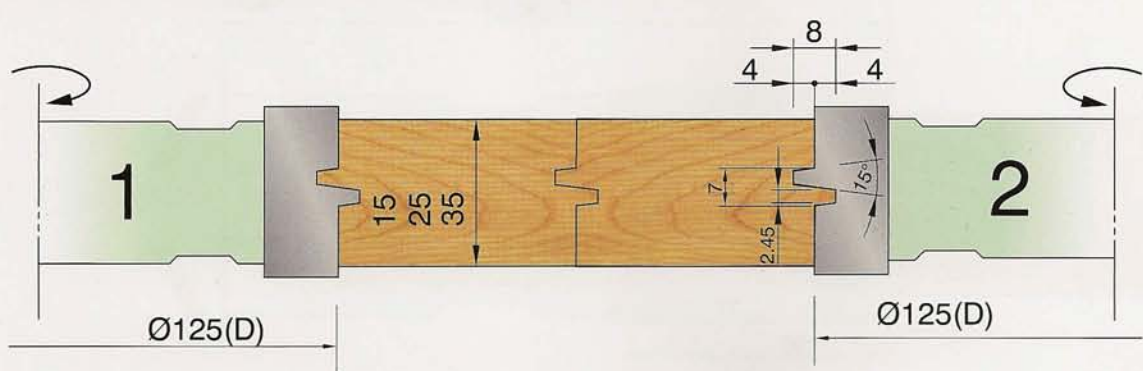
 $D125*d35*Z4$ 1SET/2PCS

TF610C

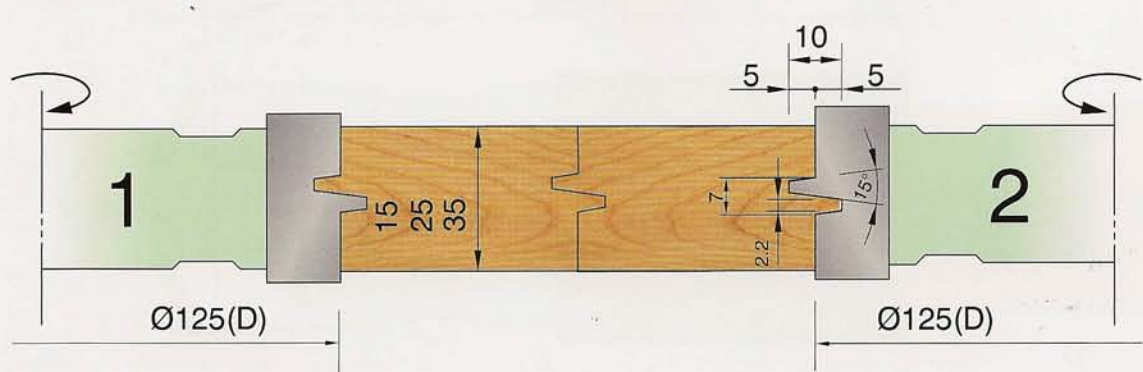
 $D125*d35*Z4$ 1SET/2PCS

Fixed Finger Jointer Cutter

(Braze T.C.T=3mm)

• Special specifications is available as per custom's order

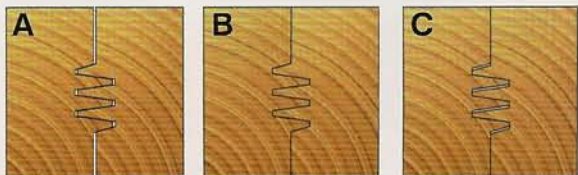

• Tight joint • Regular joint • Loose joint

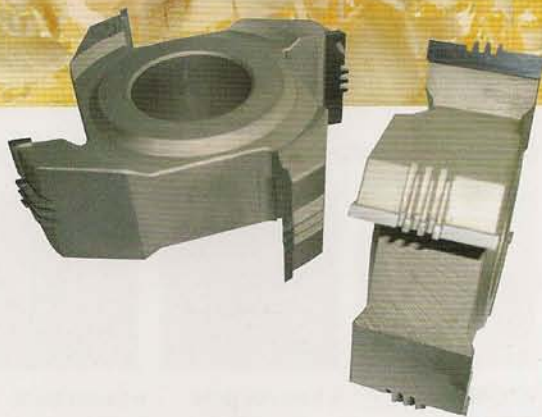

TF610D $D125*d30*Z4$ 1SET/2PCS

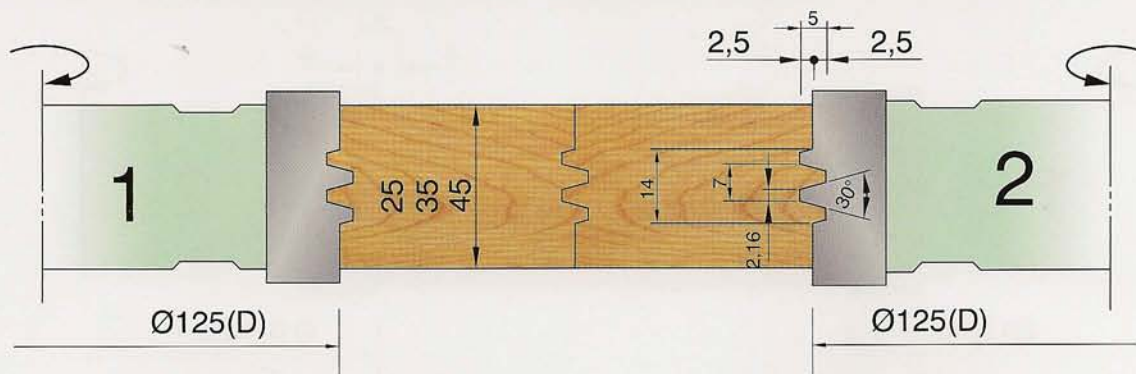

TF610E $D125*d30*Z4$ 1SET/2PCS

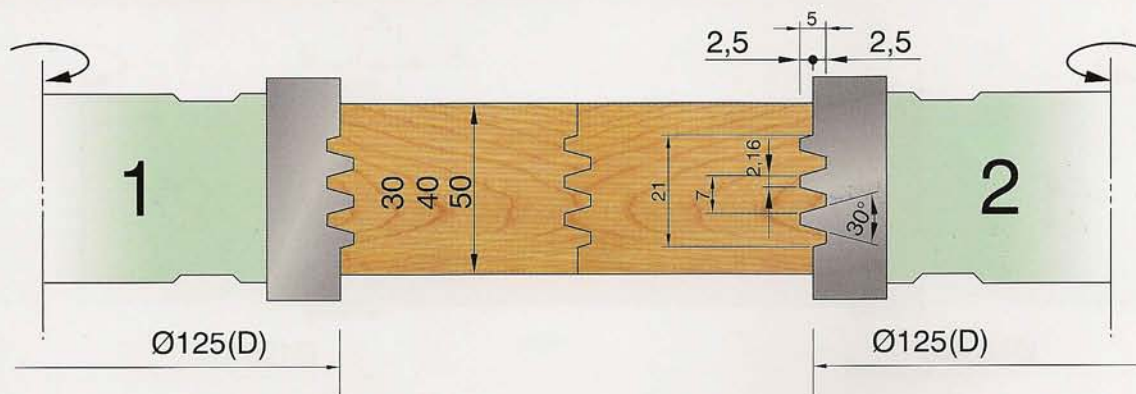

TF610F $D125*d30*Z4$ 1SET/2PCS

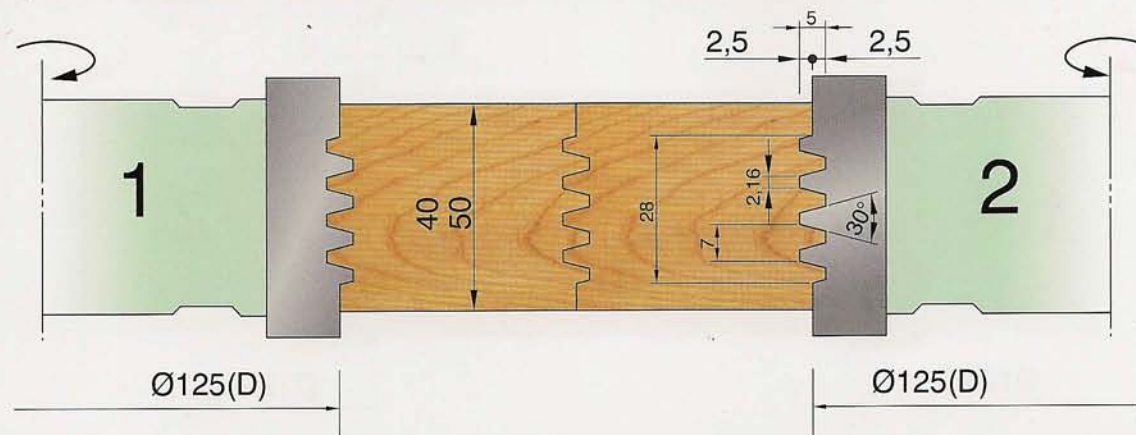



Fixed Finger Jointer Cutter

(Braze T.C.T=3mm)

• Special specifications is available as per custom's order

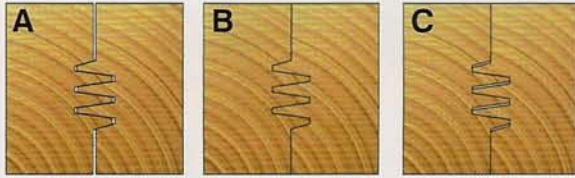

• Tight joint • Regular joint • Loose joint

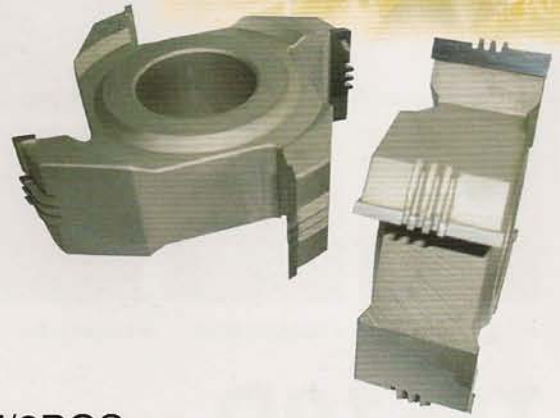

TF610G D125*d35*Z4 1SET/2PCS

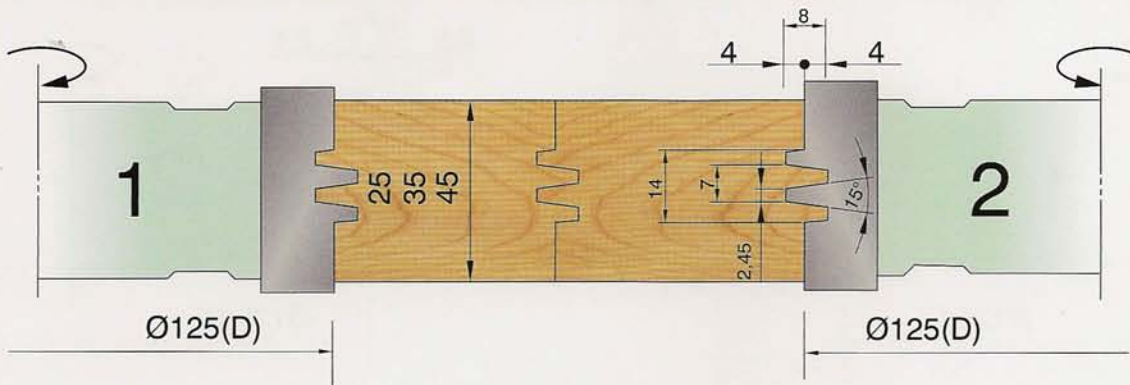

TF610H D125*d35*Z4 1SET/2PCS

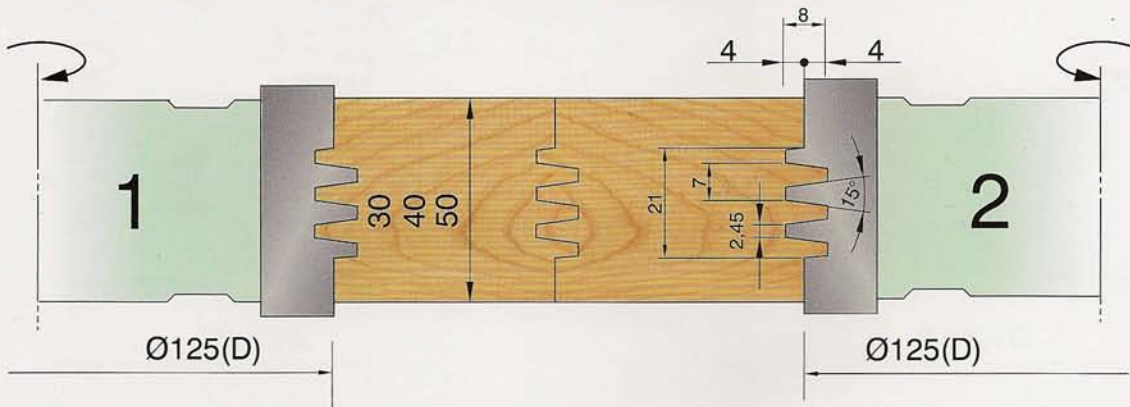

TF610J D125*d35*Z4 1SET/2PCS

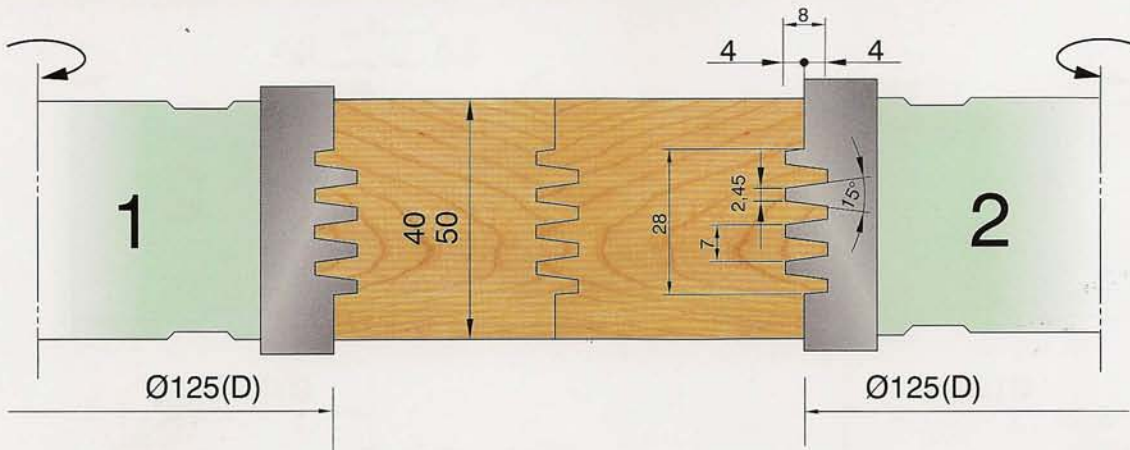

TF610 Fixed Finger Jointer Cutter

Fixed Finger Jointer Cutter

(Braze T.C.T=3mm)

• Special specifications is available as per custom's order

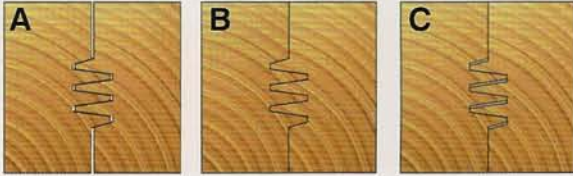

• Tight joint • Regular joint • Loose joint

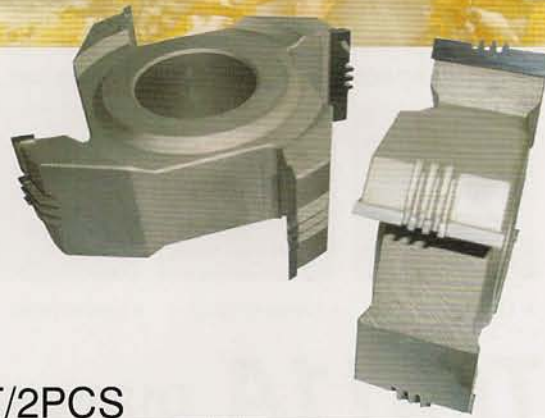

TF610K D125*d30*Z4 1SET/2PCS

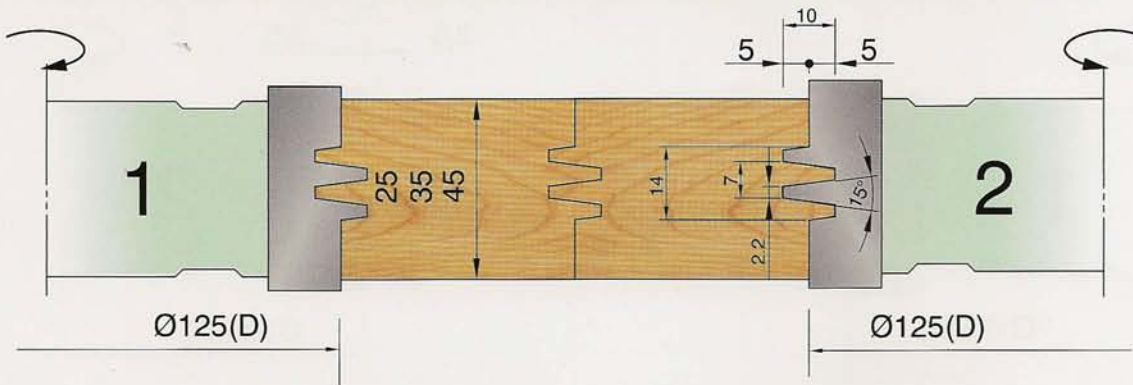

TF610L D125*d30*Z4 1SET/2PCS

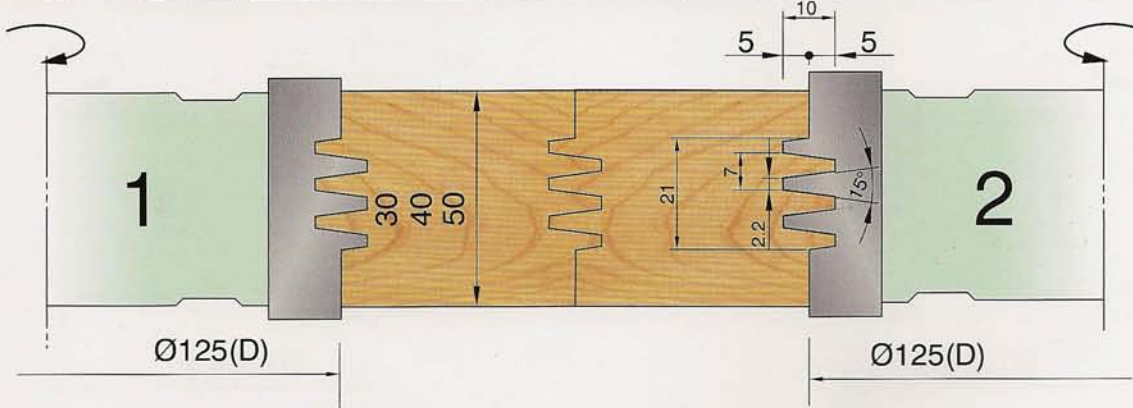

TF610M D125*d30*Z4 1SET/2PCS

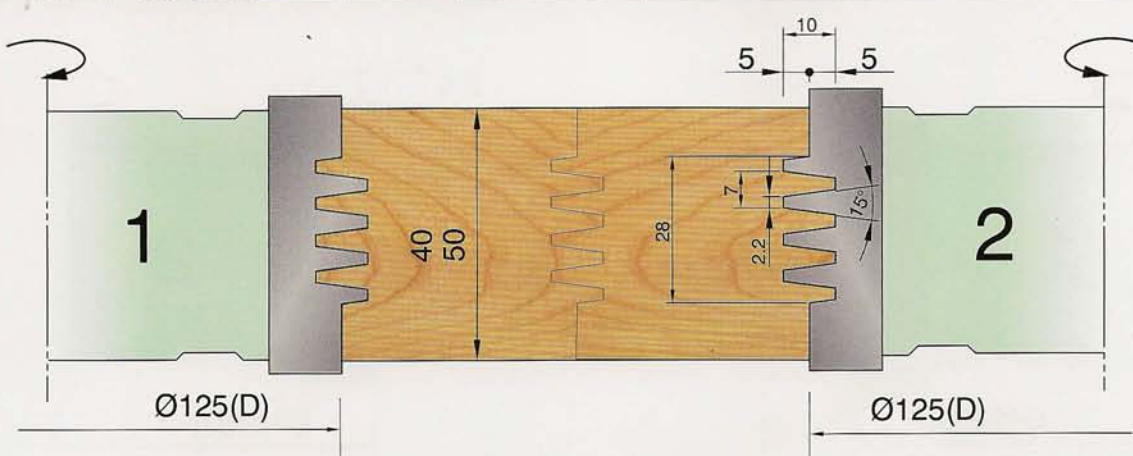



Fixed Finger Jointer Cutter

(Brazed T.C.T=3mm)

• Special specifications is available as per custom's order

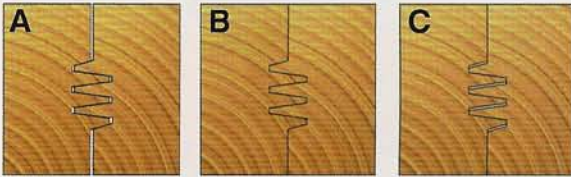

• Tight joint • Regular joint • Loose joint

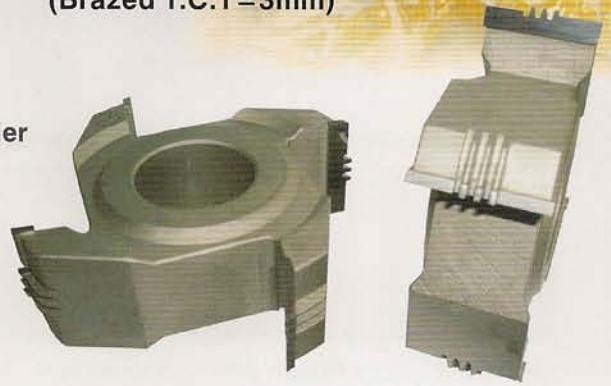

TF611A D125*d30*Z4 1SET/2PCS

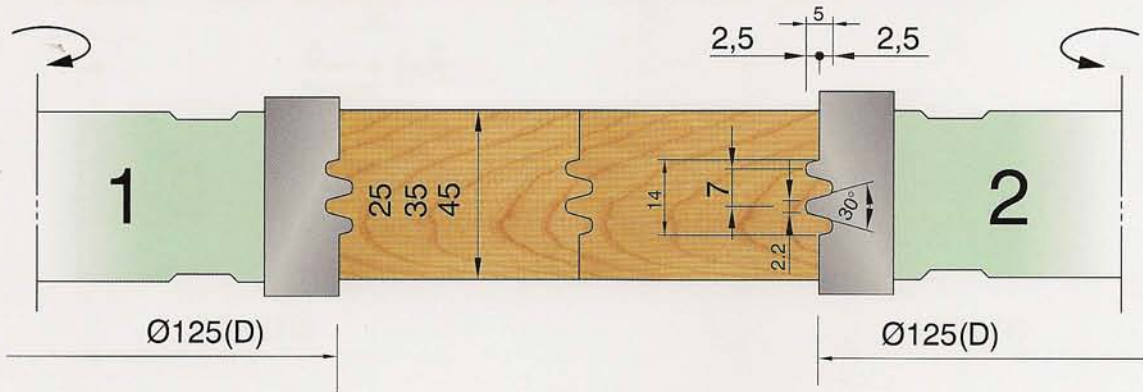

TF611B D125*d30*Z4 1SET/2PCS

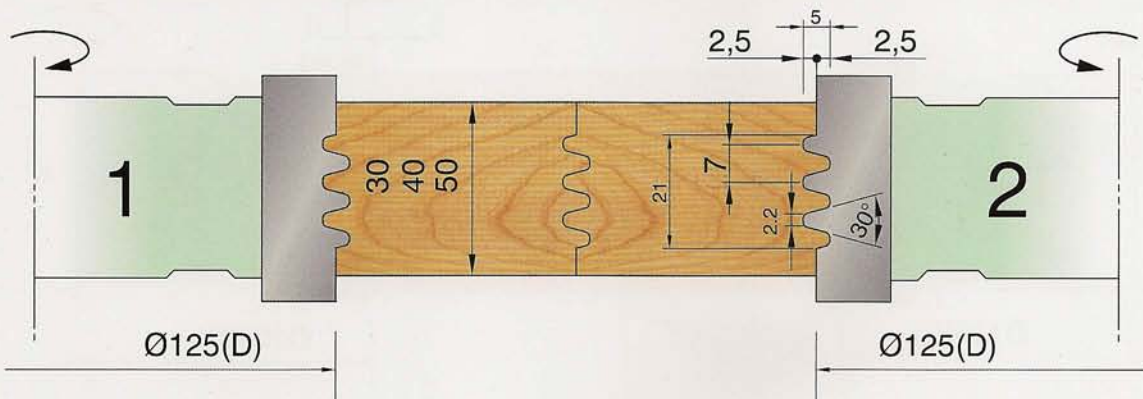

TF611C D125*d30*Z4 1SET/2PCS

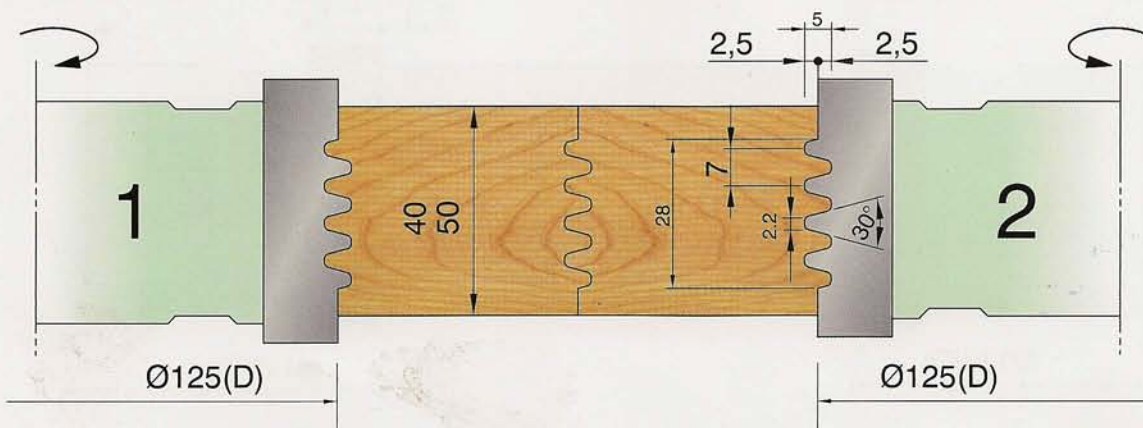

TF611 Fixed Finger Jointer Cutter

Fixed Finger Jointer Cutter

(Brazed T.C.T=3mm)

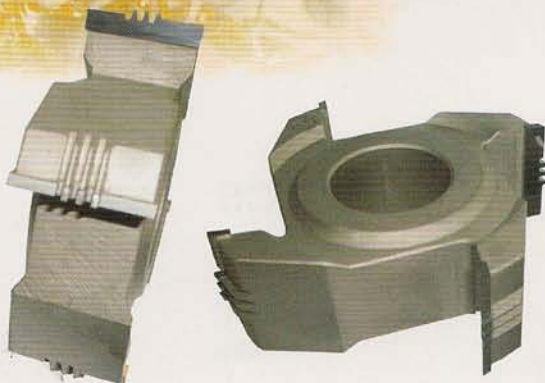

• Special specifications is available as per custom's order

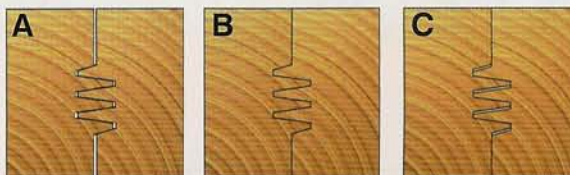

• Tight joint • Regular joint • Loose joint

TF611D D125*d35*Z4 1SET/2PCS

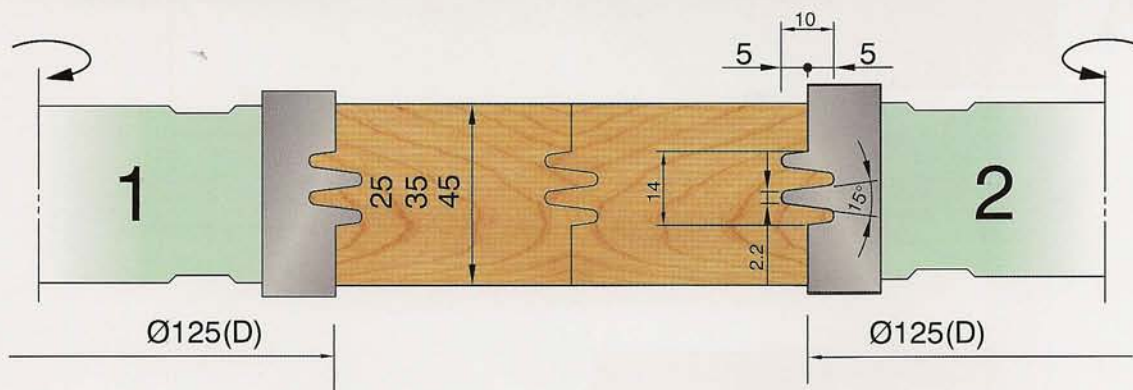

TF611E D125*d35*Z4 1SET/2PCS

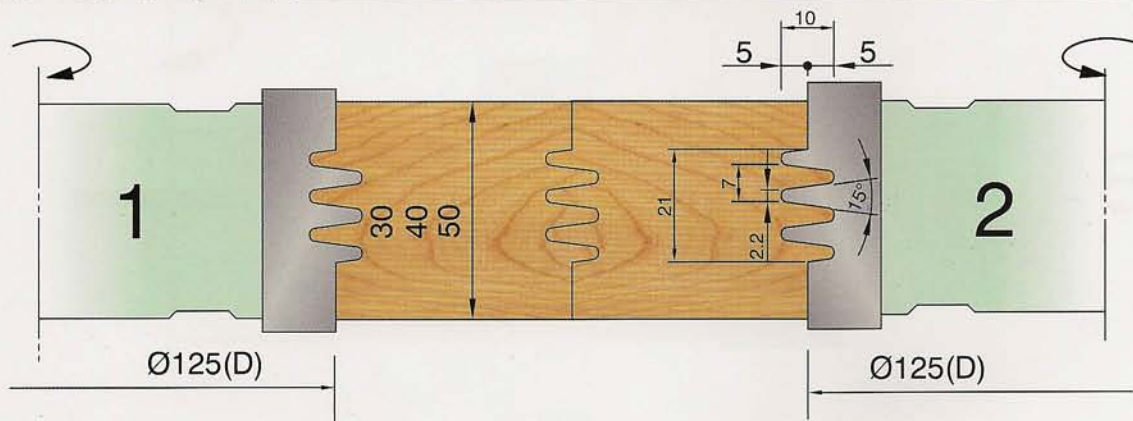

TF611F D125*d35*Z4 1SET/2PCS

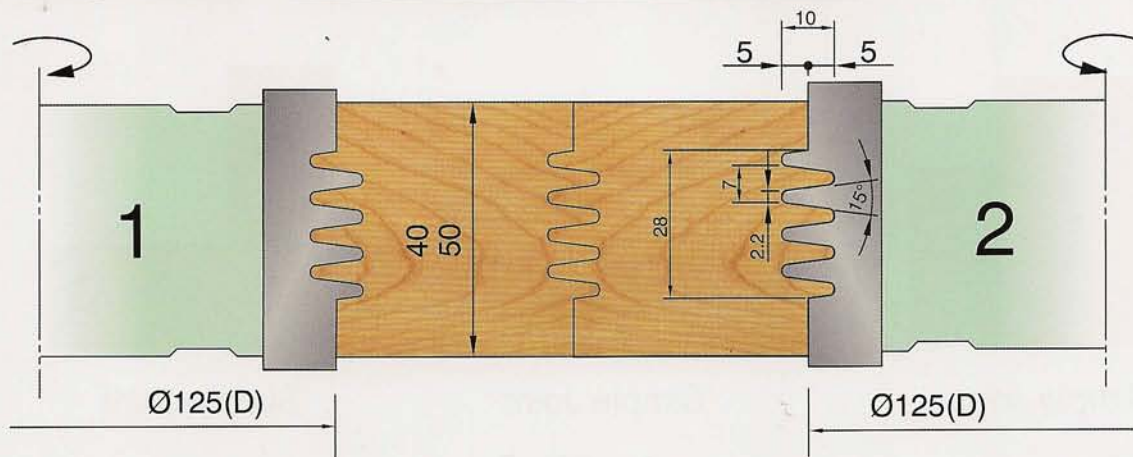



45° Miter Jointing Cutter (Braze T.C.T=4mm)

TF612 D170*(16-30mm)*d30*Z4 1SET/2PCS

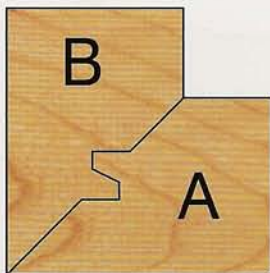
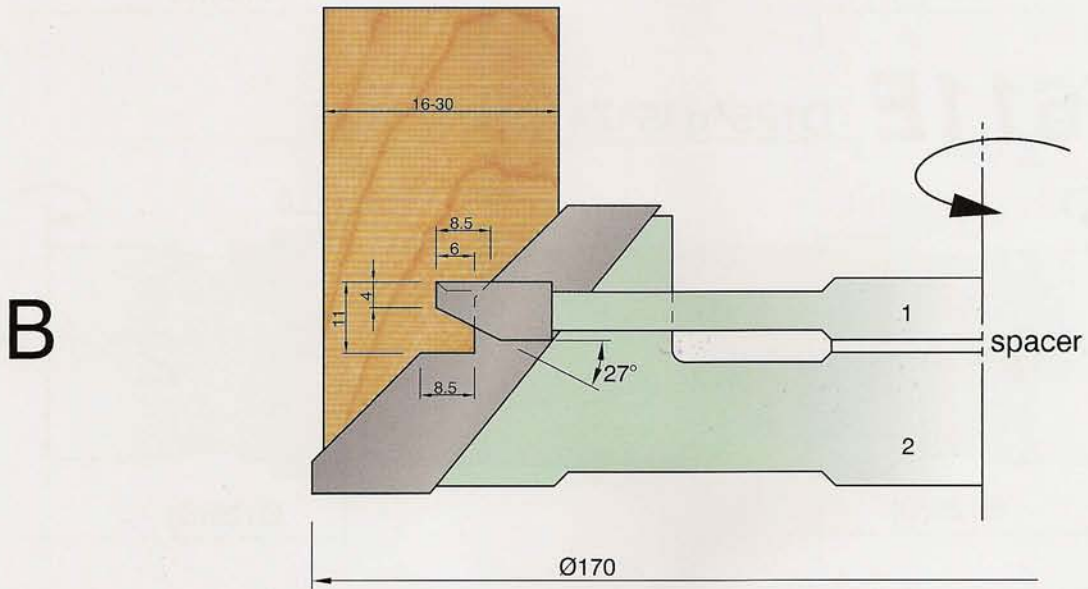
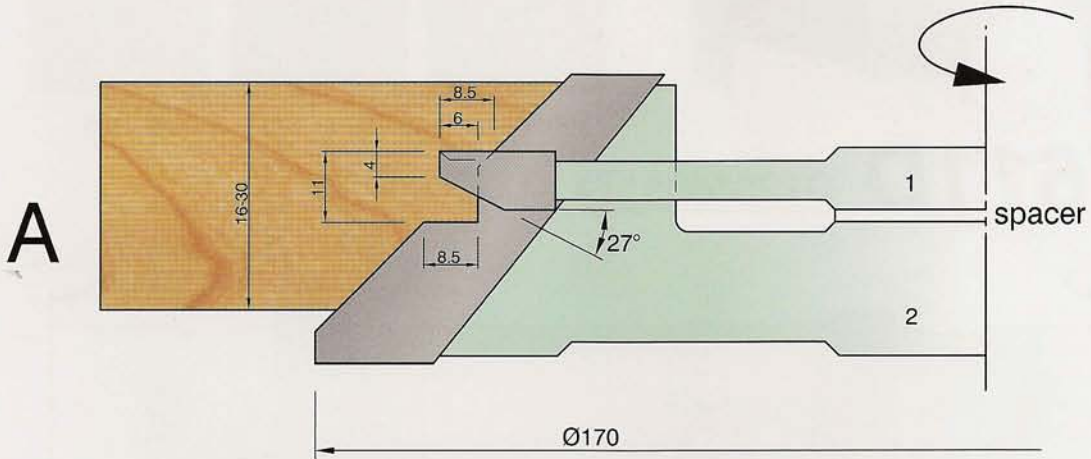

Simple Joint



Simple Joint

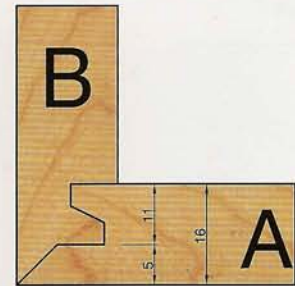

Simple Joint

TF612 45° Miter Jointing Cutter

Adjustable Finger Jointing Cutter

TF613

(Braze T.C.T=3mm)

D140*(20-70mm)*d40*Z4 1SET/2PCS

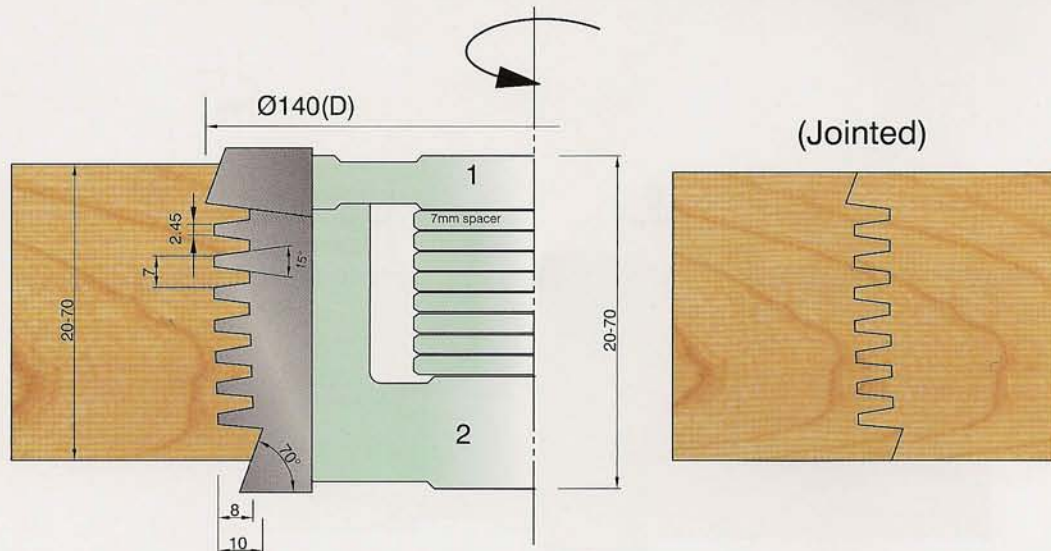

45° Miter Jointing Cutter

(Braze T.C.T=3mm)

TF615

D170*(16-30mm)*d30*Z4 1SET/2PCS

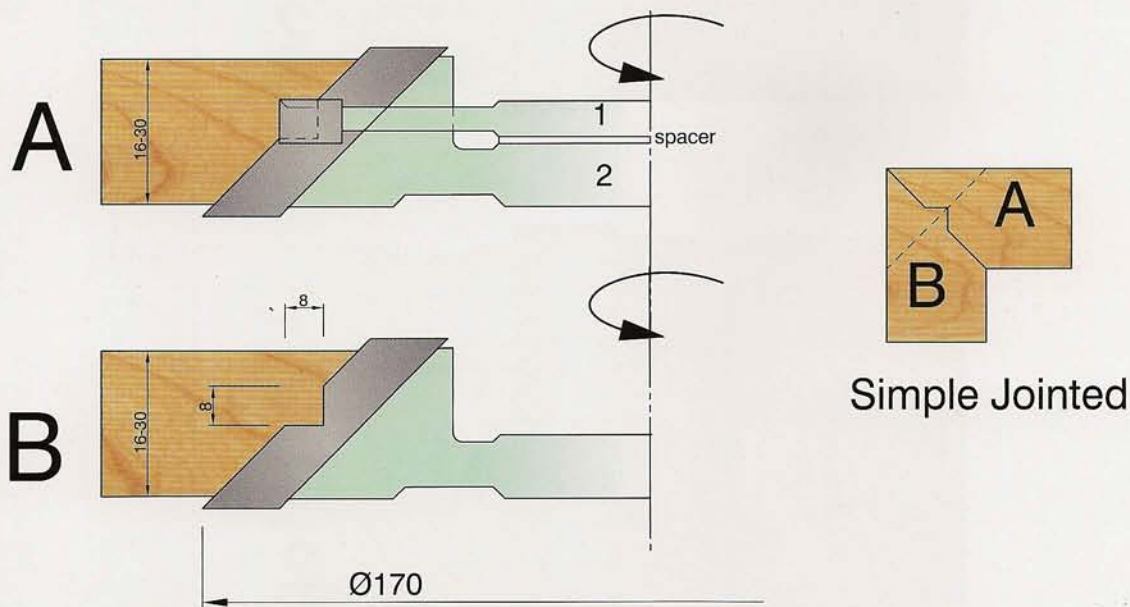

TF613/615 Adjustable Finger Jointing Cutter / 45° Miter Jointing Cutter



Adjustable Finger Jointing Cutter

(Braze T.C.T=3mm)

TF616 D125*(30-75mm)*d30*Z4 1SET/2PCS

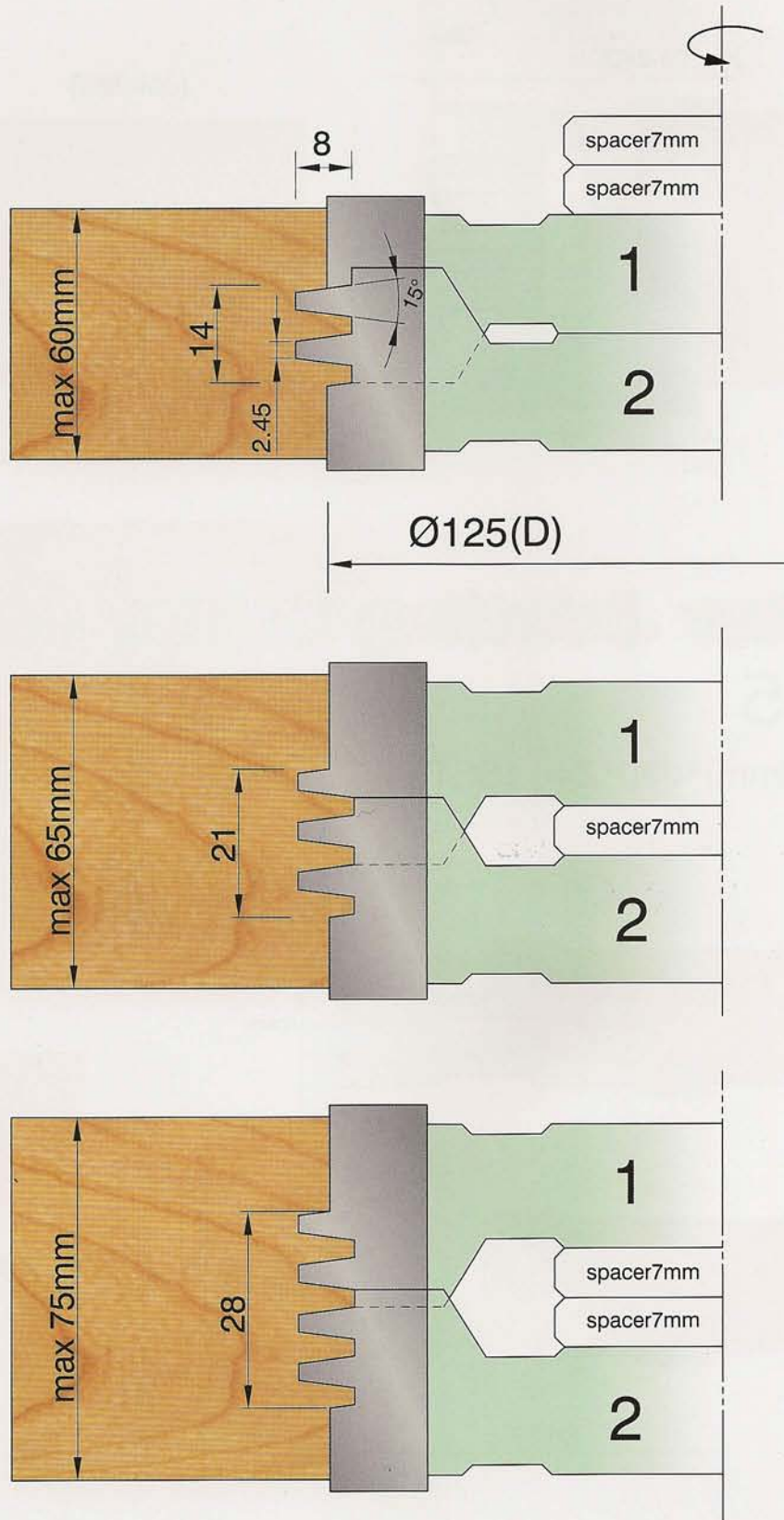

TF616 Adjustable Finger Jointing Cutter



Adjustable Finger Jointing cutter

(Braze T.C.T=3mm)

TF617 D125*(30-80mm)*d30*Z4 1SET/2PCS

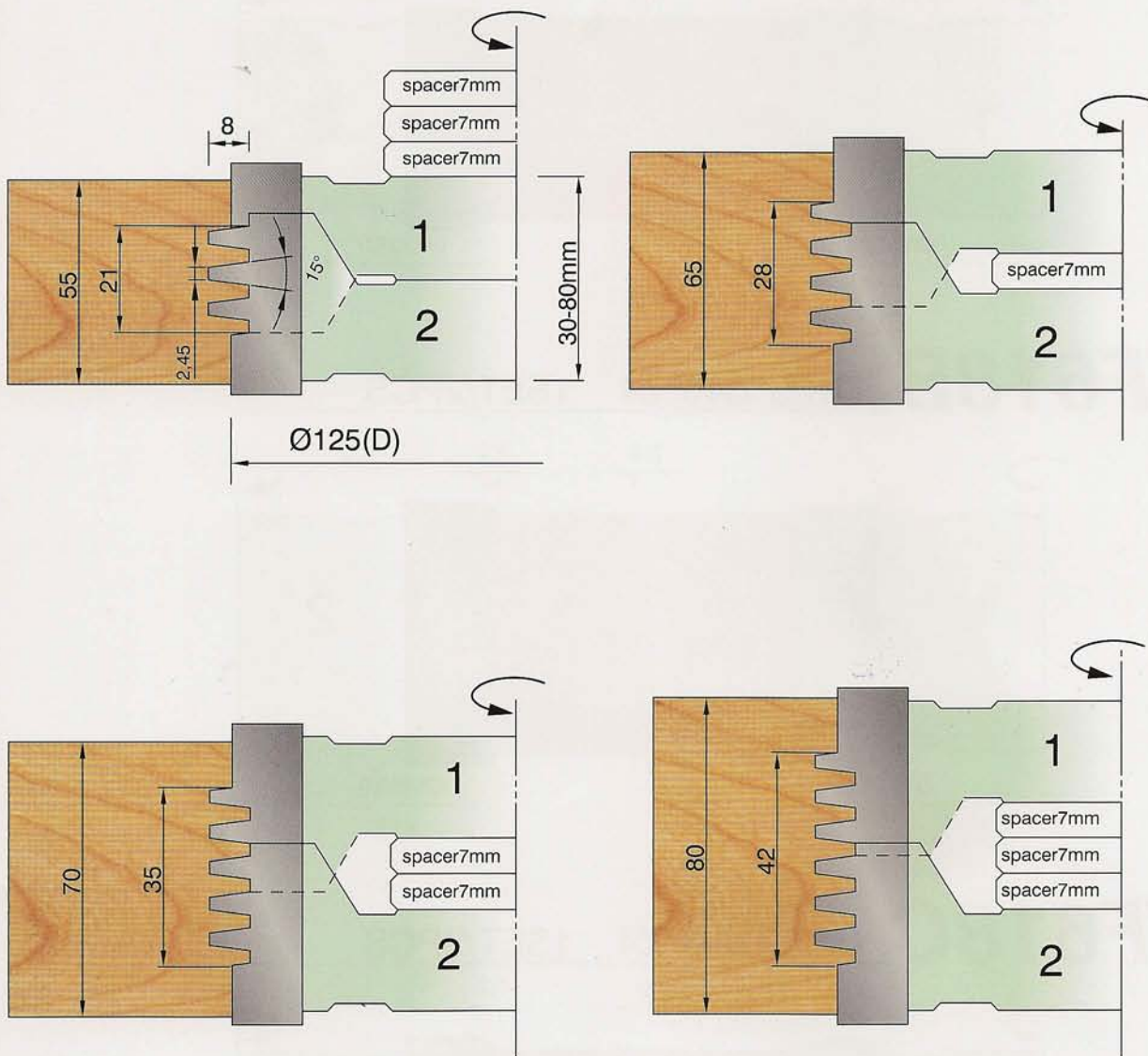



TF618 Fixed Finger Jointer Cutter

Fixed Finger Jointer Cutter

(Brazed T.C.T=4mm)

- Special specifications is available as per custom's order.

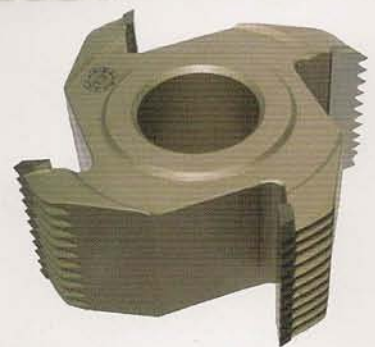

TF618A D125*d40*Z4 1SET/2PCS

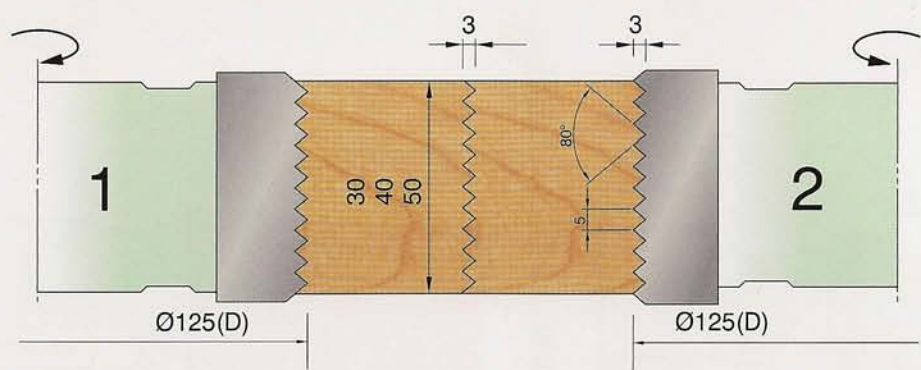

TF618B D125*d40*Z4 1SET/2PCS

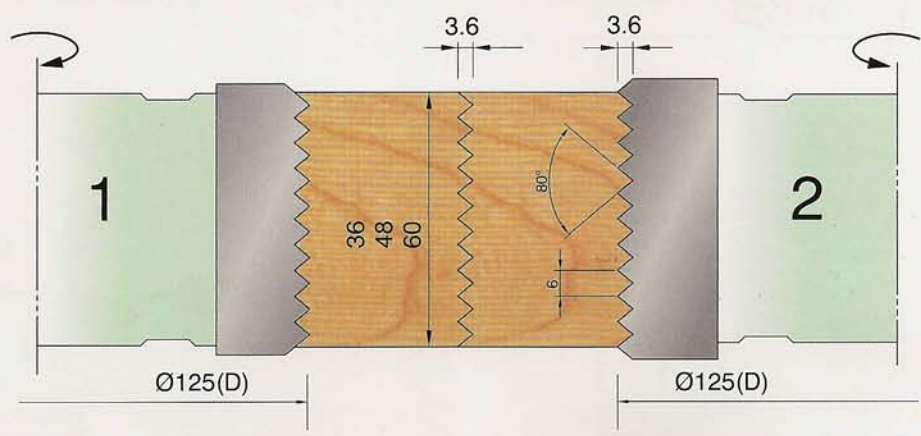

TF618C D125*d40*Z4 1SET/2PCS

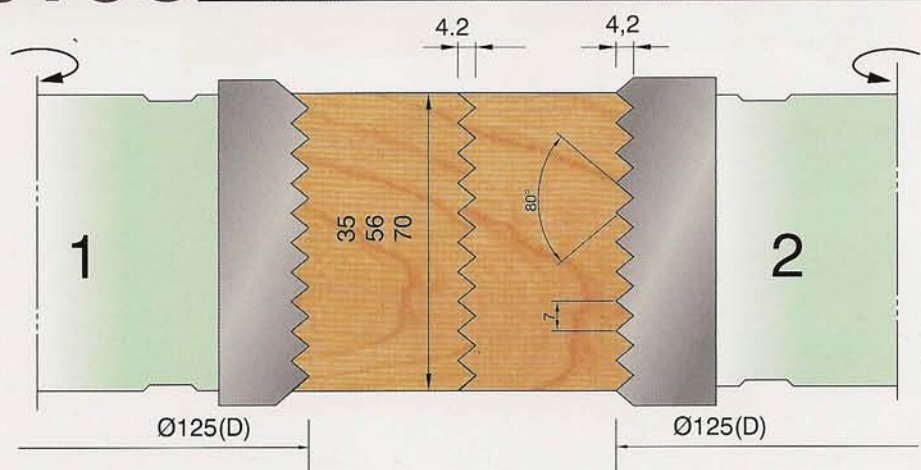



Fixed Finger Jointer Cutter

(Braze T.C.T=4mm)

- Special specifications is available as per custom's order.

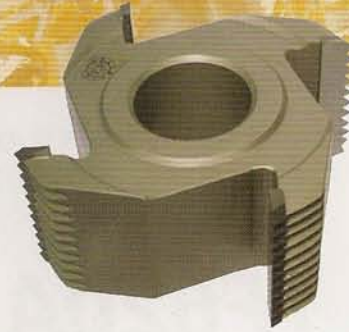
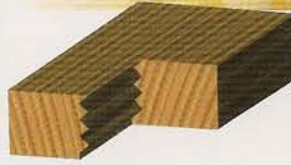

TF619

Fixed Finger Jointer Cutter

TF619A D125*d40*Z4 1SET/2PCS

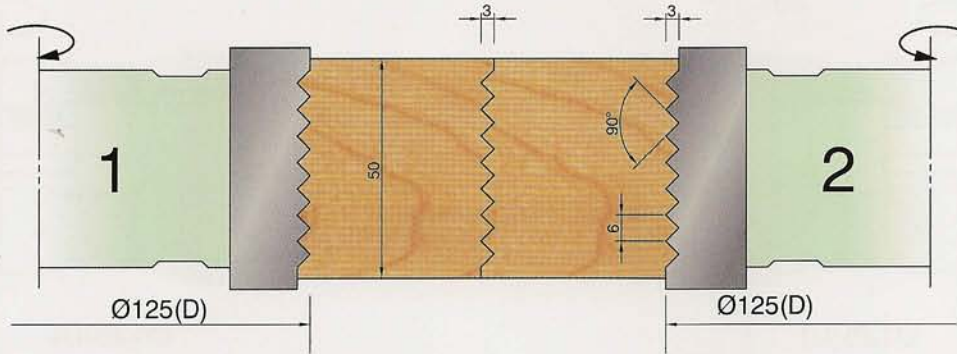

TF619B D125*d40*Z4 1SET/2PCS

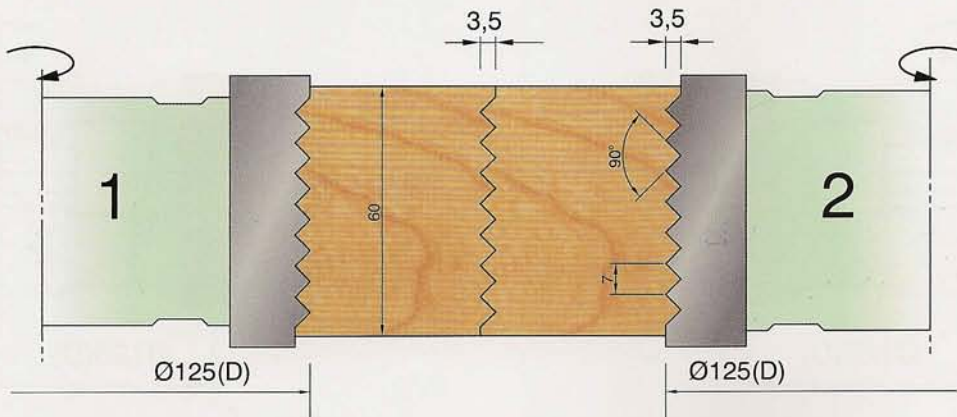

TF619C D125*d40*Z4 1SET/2PCS

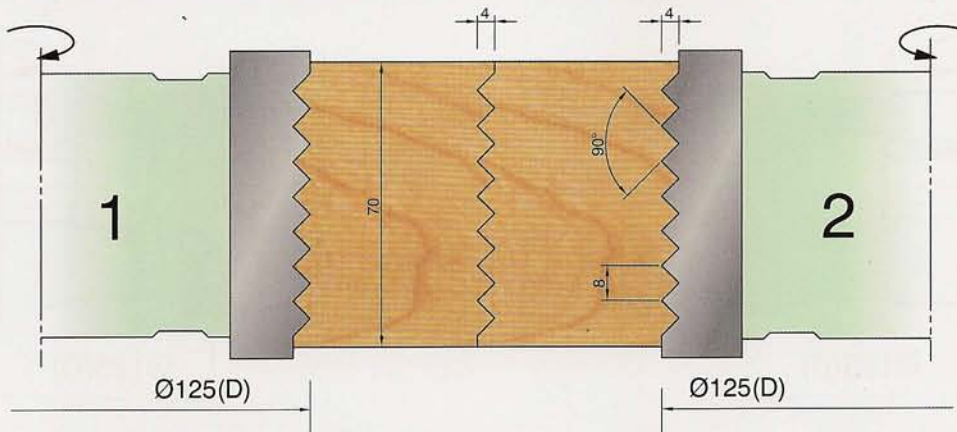



Adjustable Corner Cutter

(Brazed T.C.T=4mm)

• Special specifications is available as per custom's order.

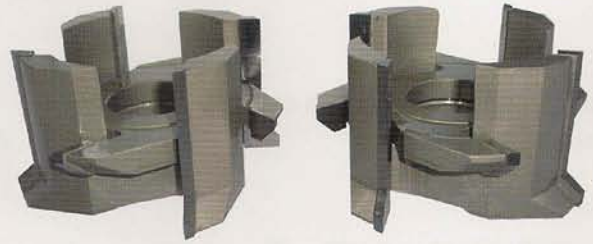

TF620A D125*(15-55mm)*d40*Z4 1SET/4PCS

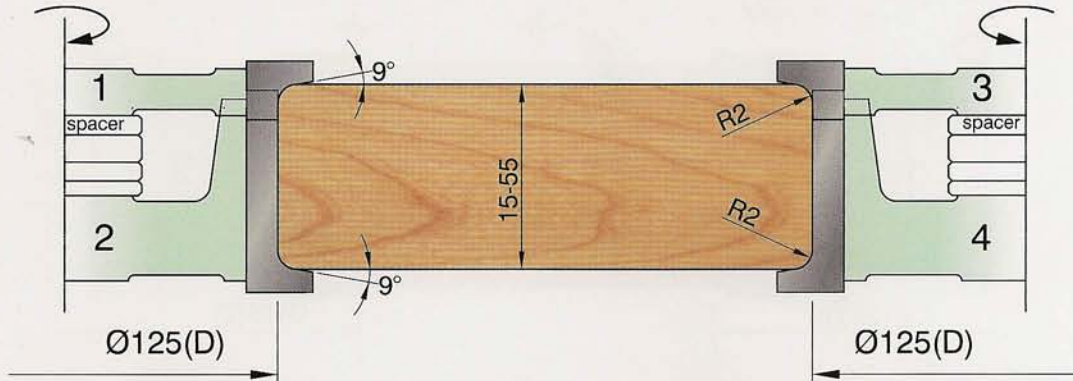

TF620B D125*(15-55mm)*d40*Z4 1SET/4PCS

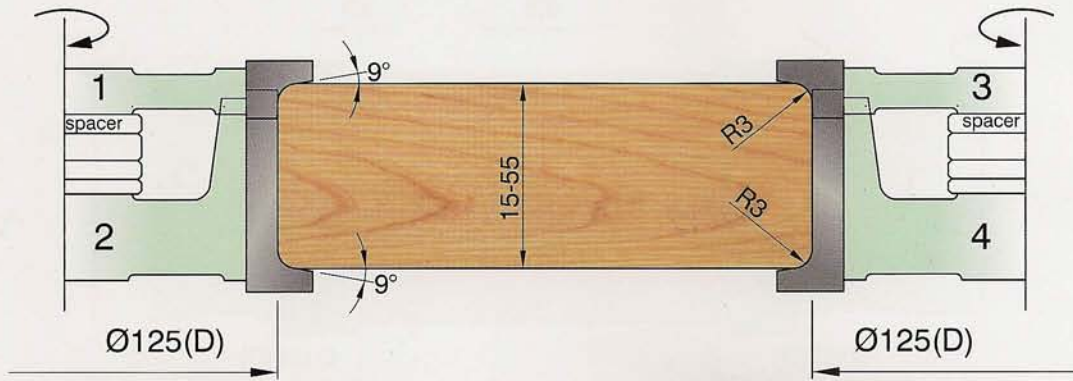

TF620C D125*(15-55mm)*d40*Z4 1SET/4PCS

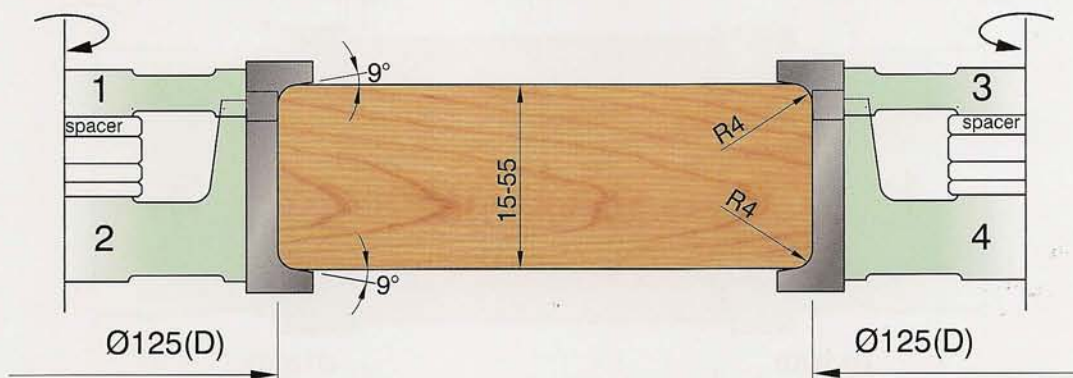

TF620 Adjustable Corner Cutter

Adjustable Corner Cutter

(Brazed T.C.T=4mm)

- Special specifications is available as per custom's order.

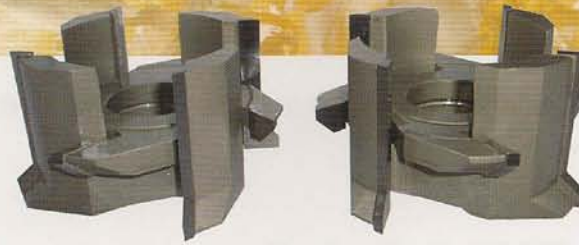

TF620D D125*(15-55mm)*d40*Z4 1SET/4PCS

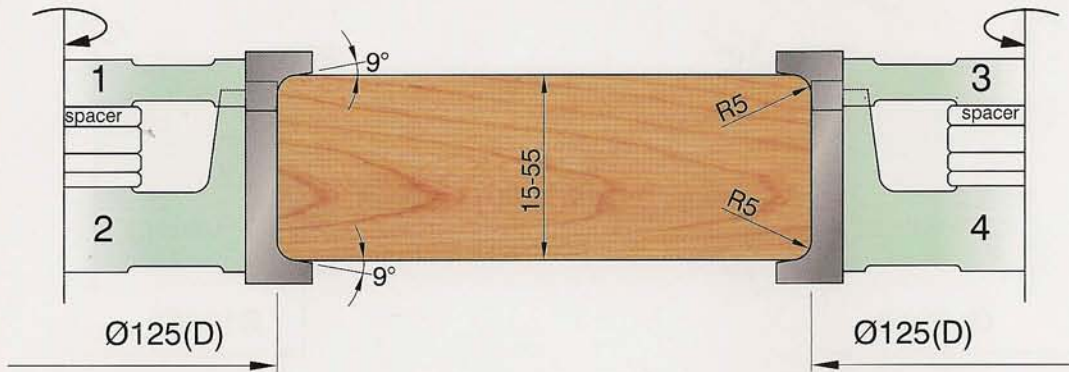

TF620E D125*(15-55mm)*d40*Z4 1SET/4PCS

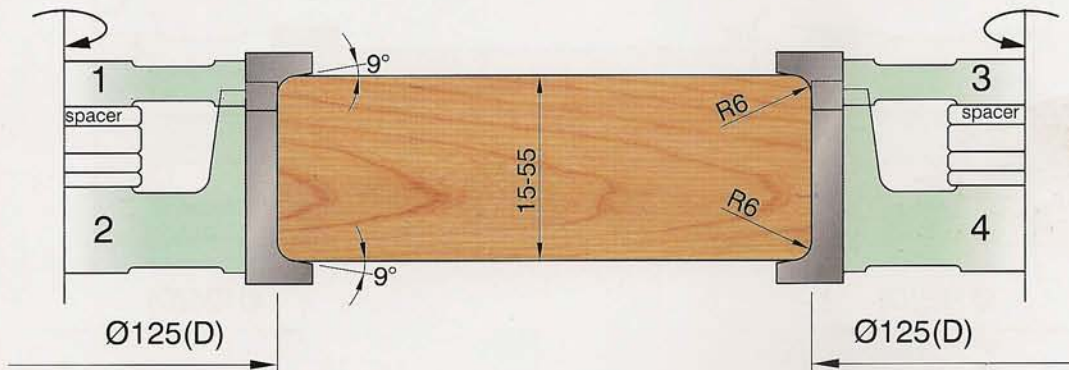

TF620F D125*(15-55mm)*d40*Z4 1SET/4PCS

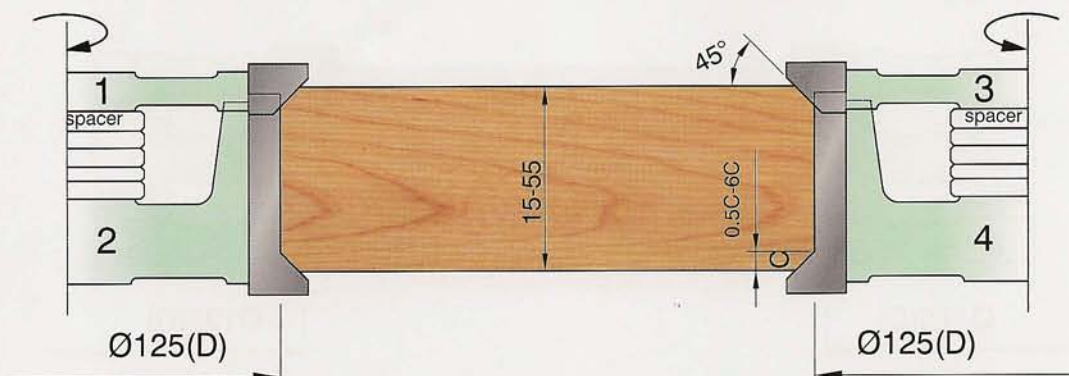



Adjustable Corner Cutter

(Brazed T.C.T=4mm)

- Special specifications is available as per custom's order.

TF621A D125*(25-70mm)*d40*Z4 1SET/6PCS

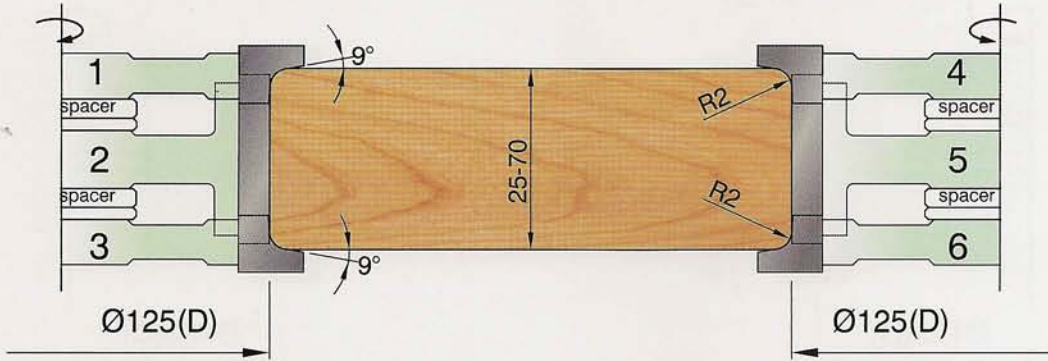

TF621B D125*(25-70mm)*d40*Z4 1SET/6PCS

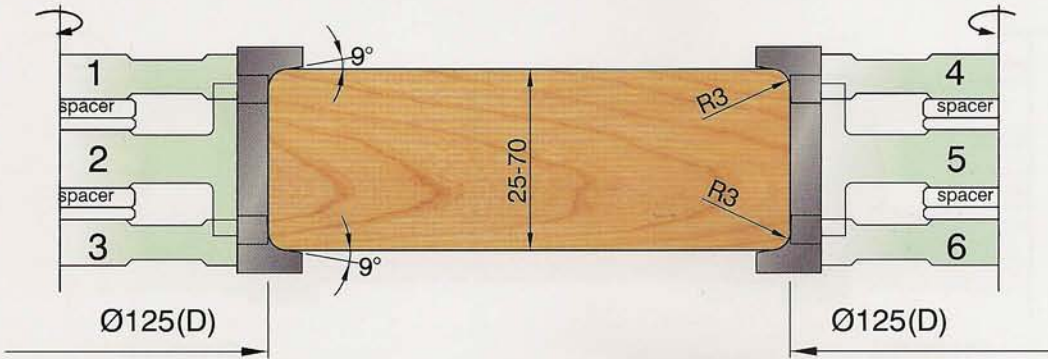

TF621C D125*(25-70mm)*d40*Z4 1SET/6PCS

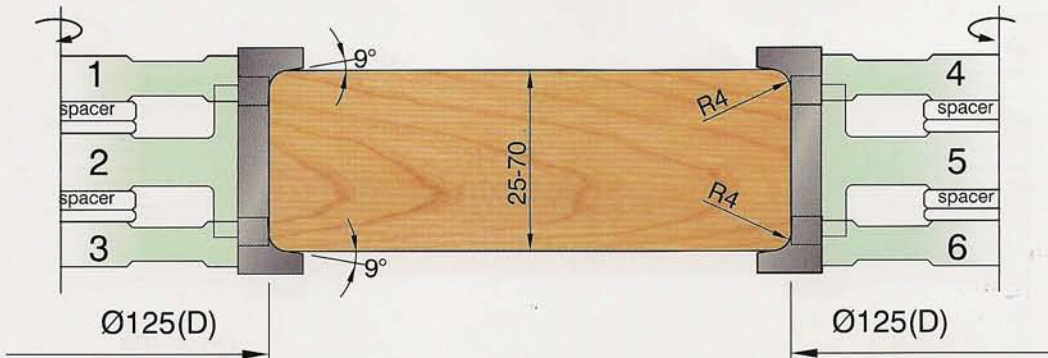

TF621 Adjustable Corner Cutter

Adjustable Corner Cutter

(Braze T.C.T=4mm)

• Special specifications is available as per custom's order.

TF621 Adjustable Corner Cutter

TF621D $D125^*(25-70mm)*d40*Z4$ 1SET/6PCS

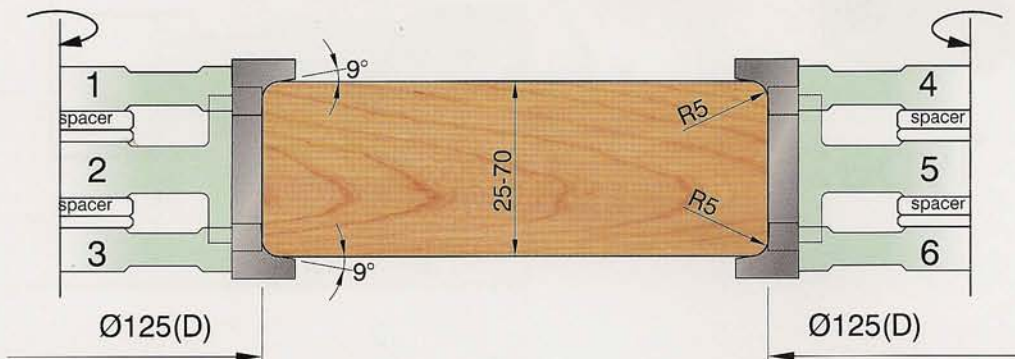

TF621E $D125^*(25-70mm)*d40*Z4$ 1SET/6PCS

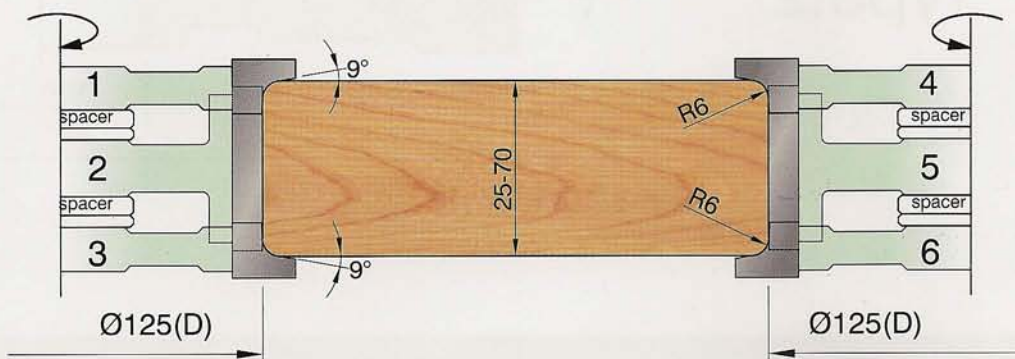

TF621F $D125^*(25-70mm)*d40*Z4$ 1SET/6PCS

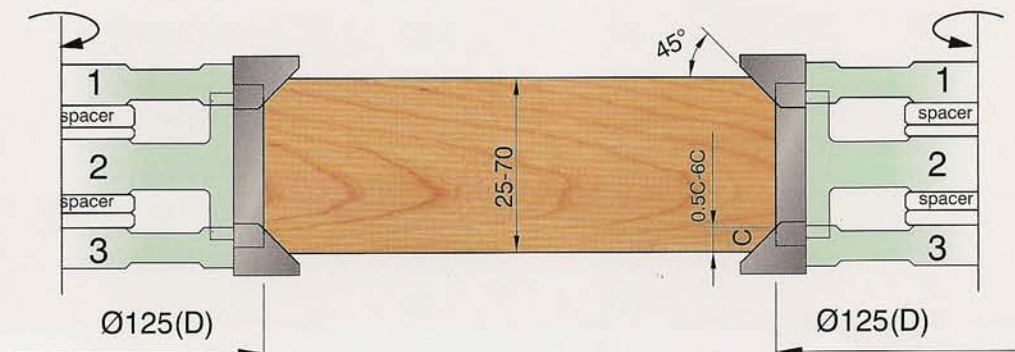



Quarter Round Cutter (Brazed T.C.T=4mm)

TF622

• Special specifications is available as per custom's order.

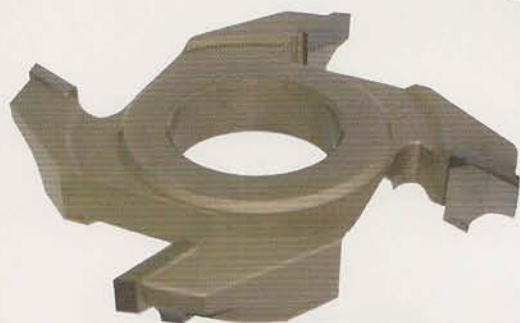

Type:1

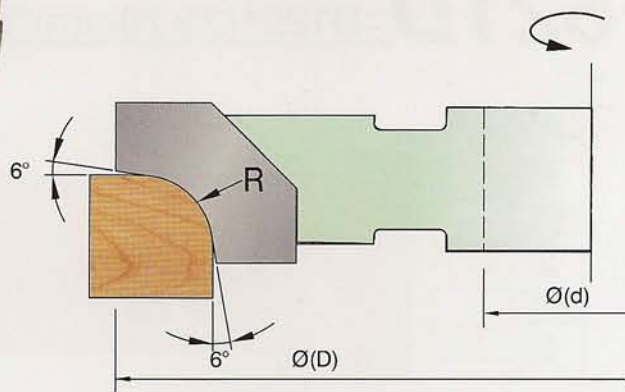

Type:2

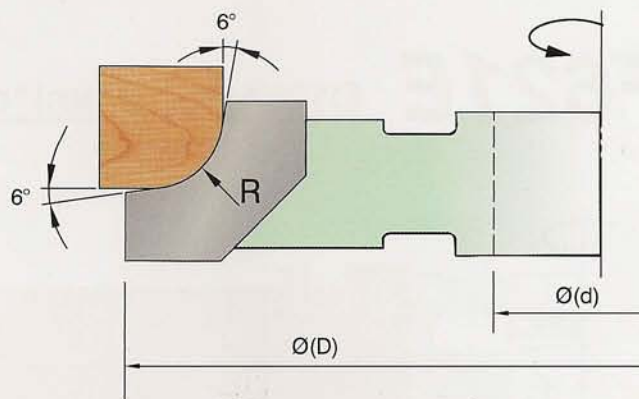

ITEM No.	Type	R mm	ϕ D mm	ϕ d mm	Z
TF622A		6	125	30/35/40	4
TF622B		8	125	30/35/40	4
TF622C		10	125	30/35/40	4
TF622D		12	140	30/35/40	4
TF622E		14	140	30/35/40	4
TF622F		16	140	30/35/40	4
TF622G		18	140	30/35/40	4
TF622H		20	150	30/35/40	4
TF622J		22	150	30/35/40	4
TF622K		25	150	30/35/40	4

Quarter Round Cutter (Brazed T.C.T=4mm)

TF623

• Special specifications is available as per custom's order.



Type:1

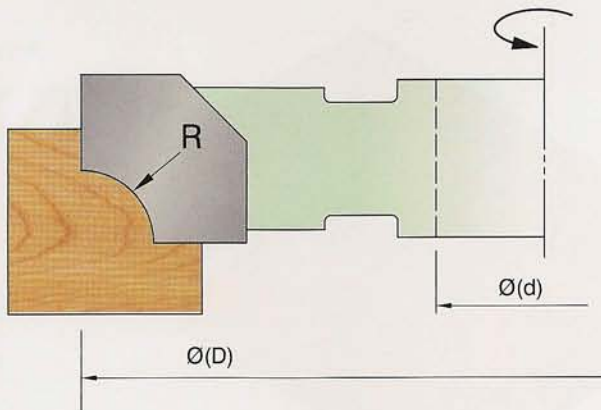

Type:2

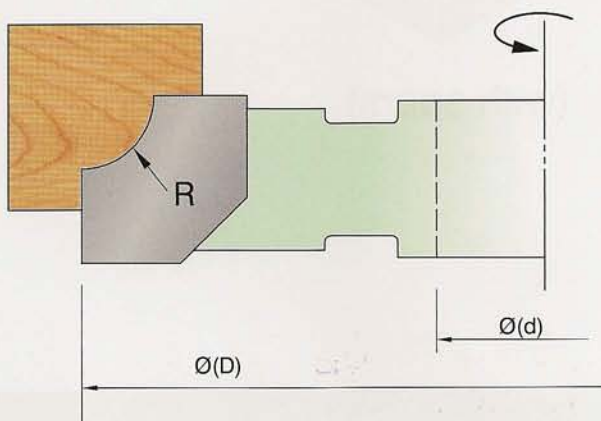

ITEM No.	Type	R mm	ϕ D mm	ϕ d mm	Z
TF623A		6	125	30/35/40	4
TF623B		8	125	30/35/40	4
TF623C		10	125	30/35/40	4
TF623D		12	125	30/35/40	4
TF623E		14	140	30/35/40	4
TF623F		16	140	30/35/40	4
TF623G		18	140	30/35/40	4
TF623H		20	150	30/35/40	4
TF623J		22	150	30/35/40	4
TF623K		24	150	30/35/40	4



Grooving Cutter (Braze T.C.T=4mm)

TF625

• Special specifications is available as per custom's order.

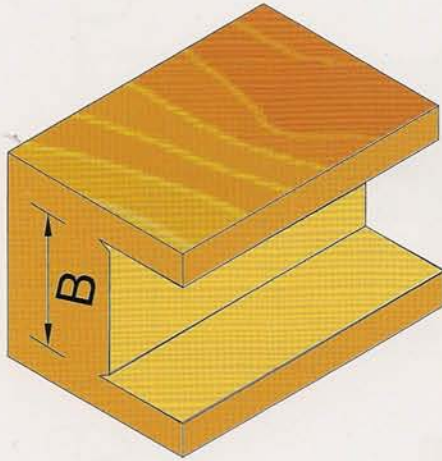

(with spurs)

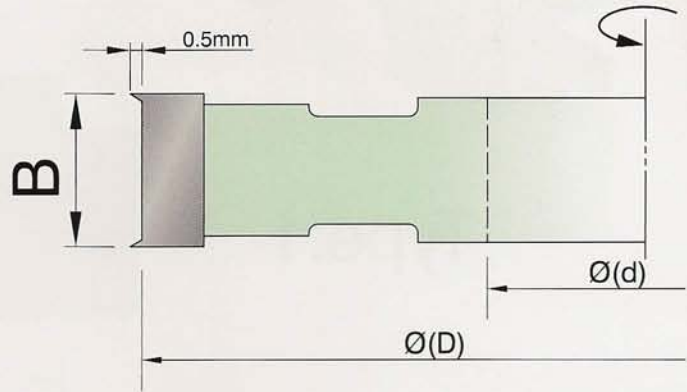

ITEM No.	B mm	ϕ D mm	ϕ d mm	Z
TF625A	7	150	30/35/40	4/6
TF625B	9	150	30/35/40	4/6
TF625C	11	150	30/35/40	4/6
TF625D	13	150	30/35/40	4/6
TF625E	15	150	30/35/40	4/6
TF625F	17	150	30/35/40	4/6
TF625G	19	150	30/35/40	4/6
TF625H	21	150	30/35/40	4/6
TF625J	23	150	30/35/40	4/6
TF625K	25	150	30/35/40	4/6
TF625L	27	150	30/35/40	4/6
TF625M	29	150	30/35/40	4/6
TF625N	31	150	30/35/40	4/6

Grooving Cutter

(Braze T.C.T=4mm)

TF626

• Special specifications is available as per custom's order.

Type:1

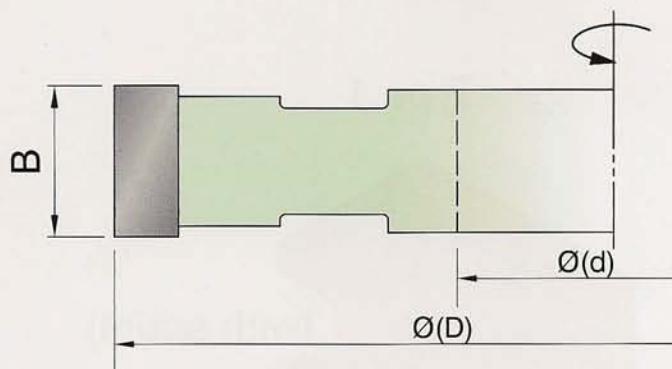
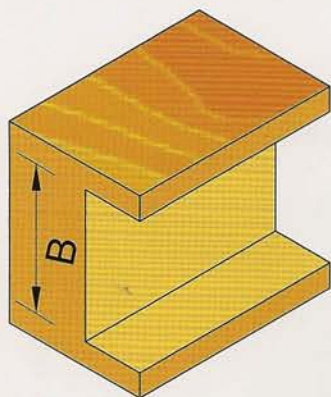

Type:2

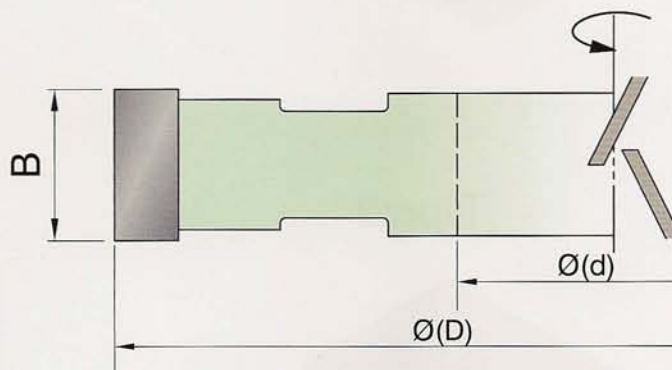
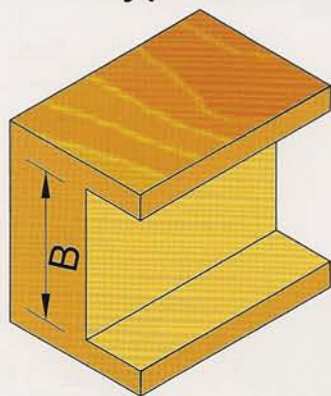

ITEM No.	Type	B mm	ϕ D mm	ϕ d mm	Z
TF626A		6	125	30/35/40	4/6
TF626B		8	125	30/35/40	4/6
TF626C		10	125	30/35/40	4/6
TF626D		12	125	30/35/40	4/6
TF626E		14	125	30/35/40	4/6
TF626F		16	125	30/35/40	4/6
TF626G		18	125	30/35/40	4/6
TF626H		20	125	30/35/40	4/6
TF626J		22	125	30/35/40	4/6
TF626K		24	125	30/35/40	4/6
TF626L		26	125	30/35/40	4/6
TF626M		28	125	30/35/40	4/6
TF626N		30	125	30/35/40	4/6



Adjustable Grooving Cutter

TF627

(Braze T.C.T=4mm)

• Special specifications is available as per custom's order.

Type:1

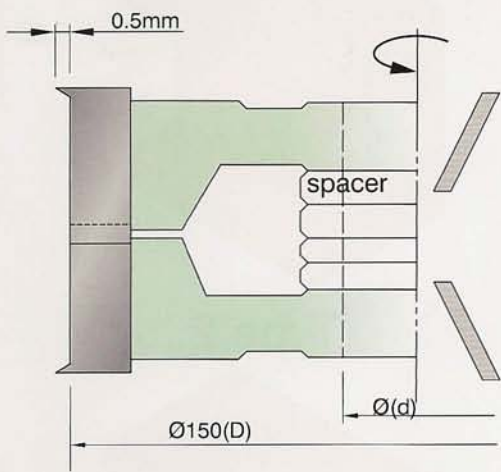
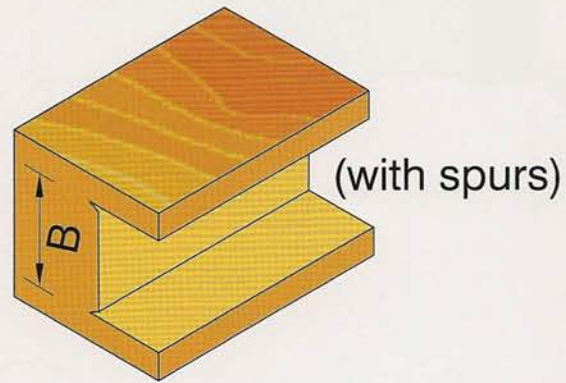

Type:2

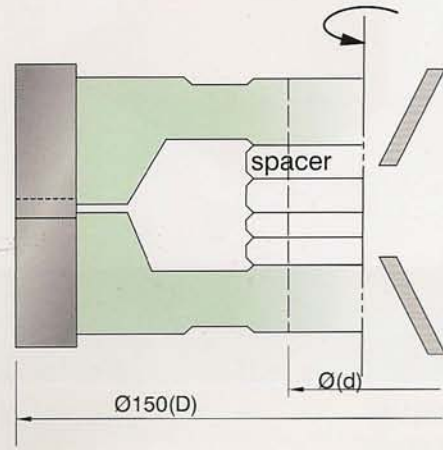
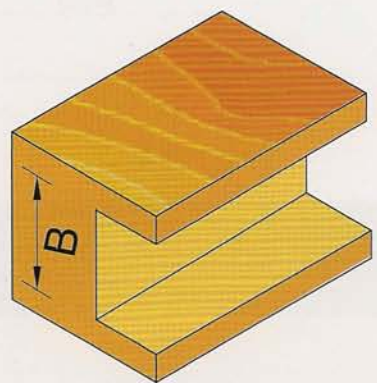

ITEM No.	Type	B mm	φ D mm	φ d mm	Z
TF627A		20-34	150	30/35/40	4
TF627B		33-60	150	30/35/40	4
TF627C		58-100	150	30/35/40	4

Flute Cutter (Brazed T.C.T=4mm)

TF628

TF628 Flute Cutter

- Special specifications is available as per custom's order.

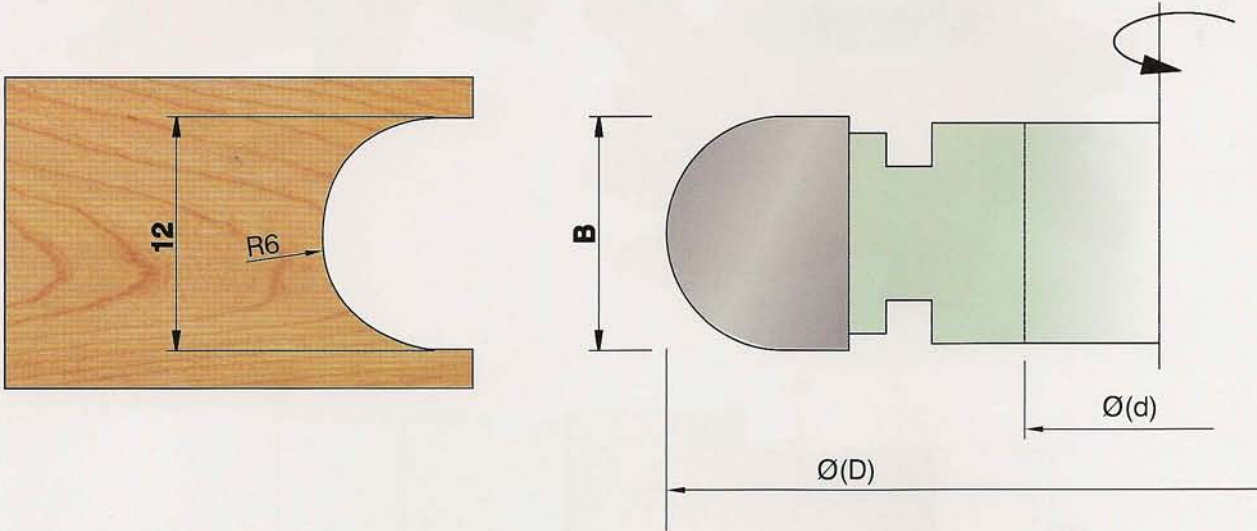

Flute Cutter

ITEM No.	R mm	B mm	ϕD mm	ϕd mm	Z
TF628A	6	12	125	30/35/40	4
TF628B	8	16	125	30/35/40	4
TF628C	10	20	125	30/35/40	4
TF628D	12	24	125	30/35/40	4
TF628E	14	28	140	30/35/40	4
TF628F	16	32	140	30/35/40	4
TF628G	18	36	140	30/35/40	4



Half Round Cutter (Brazed T.C.T=4mm)

TF629

• Special specifications is available as per custom's order.

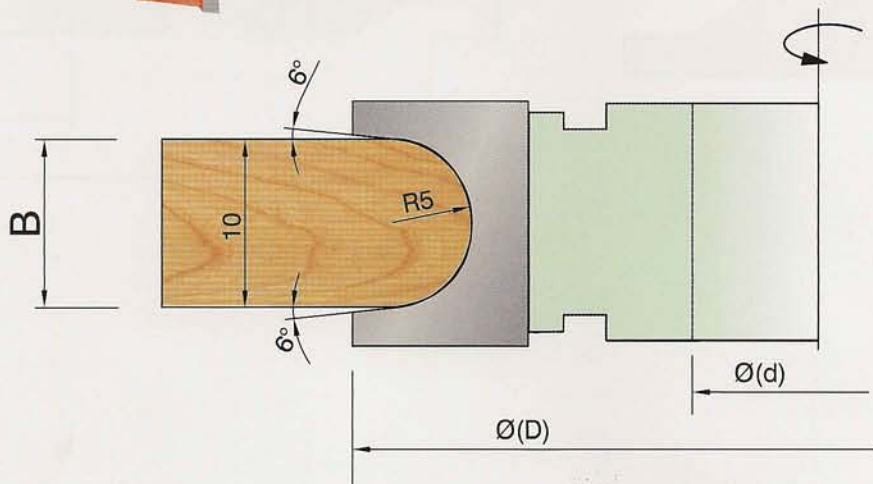

Half Round Cutter					
ITEM No.	R mm	B mm	ϕ D mm	ϕ d mm	Z
TF629A	5	10	125	30/35/40	4
TF629B	6	12	125	30/35/40	4
TF629C	8	16	125	30/35/40	4
TF629D	10	20	125	30/35/40	4
TF629E	12	24	140	30/35/40	4
TF629F	13	26	140	30/35/40	4
TF629G	15	30	140	30/35/40	4
TF629H	16	32	140	30/35/40	4
TF629J	18	36	150	30/35/40	4
TF629K	20	40	150	30/35/40	4

TF629 Half Round Cutter

Planer Knife-HSS Solid

TF701

TF701 Planer Knife-HSS Solid

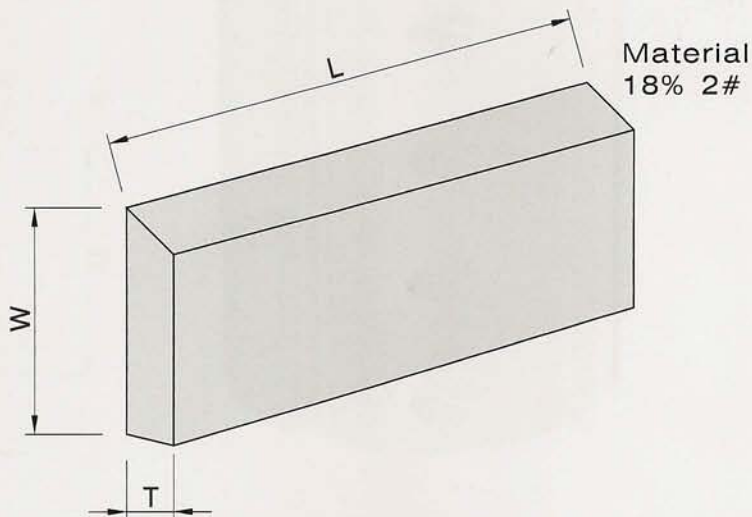

H.S.S Planer Knife

ITEM No.	Length mm	Width mm	Thickness mm
TF701A	50	30	3
TF701B	60	30	3
TF701C	80	30	3
TF701D	100	30	3
TF701E	130	30	3
TF701F	150	30	3
TF701G	180	30	3
TF701H	200	30	3
TF701J	230	30	3
TF701K	250	30	3
TF701L	300	30	3
TF701M	355	30	3
TF701N	406	30	3
TF701P	460	30	3
TF701Q	510	30	3
TF701R	610	30	3
TF701S	610	38 (HSS Inlay)	6



Planer Knife-T.C.T Inlay TF702

TF702 Planer Knife-T.C.T Inlay

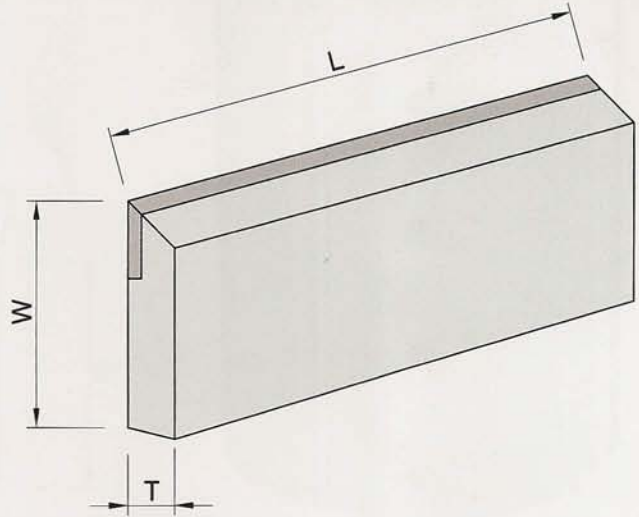

T.C.T Planer Knife			
ITEM No.	Length mm	Width mm	Thickness mm
TF702A	50	30	3
TF702B	60	30	3
TF702C	80	30	3
TF702D	100	30	3
TF702E	130	30	3
TF702F	150	30	3
TF702G	180	30	3
TF702H	200	30	3
TF702J	230	30	3
TF702K	250	30	3
TF702L	300	30	3
TF702M	355	30	3
TF702N	406	30	3
TF702P	460	30	3
TF702Q	510	30	3
TF702R	610	30	3
TF702S	610	38	6



Corrugate Planer Knife-HSS Solid TF703

TF703 Corrugate Planer Knife-HSS Solid

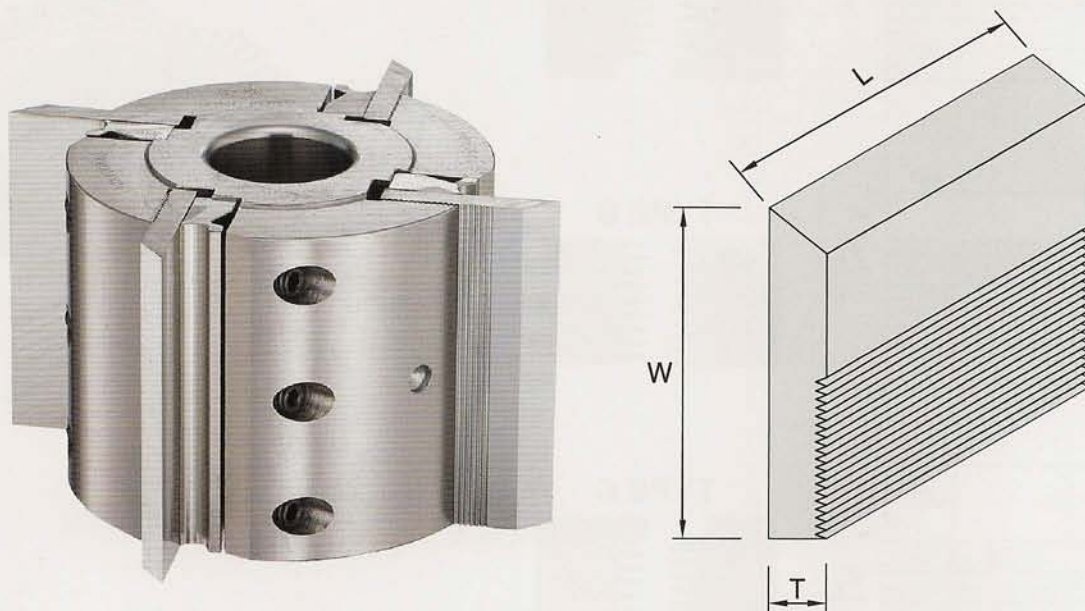

H.S.S Planer Knife

ITEM No.	Length mm	Width mm	Thickness mm
TF703A	50	50/60/70/80/90	8
TF703B	60	50/60/70/80/90	8
TF703C	80	50/60/70/80/90	8
TF703D	100	50/60/70/80/90	8
TF703E	130	50/60/70/80/90	8
TF703F	150	50/60/70/80/90	8
TF703G	180	50/60/70/80/90	8
TF703H	200	50/60/70/80/90	8
TF703J	230	50/60/70/80/90	8
TF703K	635	50/60/70/80/90	8
TF703L	635	30/50	6



Finger Jointer Cutter (Brazed T.C.T)

TF705

TF705 Finger Jointer Cutter

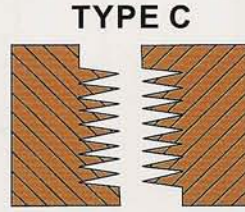
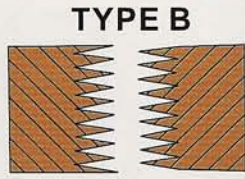
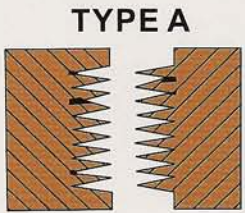
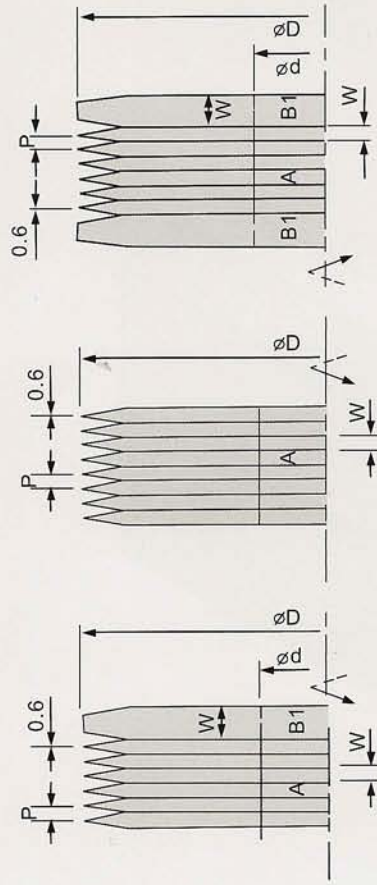

Finger Jointer Cutter				
ITEM No.	ϕD mm	B mm	ϕd mm	Z
TF705A	160	3.7	50	2
TF705B	160	3.7	70	2
TF705C	160	4.0	50	2
TF705D	160	4.0	70	2
TF705E	160	10	50	2
TF705F	160	10	70	2
TF705G	160	4.0	50	4
TF705H	160	4.0	70	4
TF705J	160	10	50	4
TF705K	160	10	70	4
TF705L	210	4.0	70	4
TF705M	210	10	70	4

Saw Blade (Brazed T.C.T)

TF706

- Special specifications is available as per custom's order
- For cutting wood.MDF.aluminium.acrylic.

For Cross Cut

ITEM No.	ϕD	Thickness	ϕd	Z
TF706A	205	2.2	25.4/30	60
TF706B	205	3.0	25.4/30	80
TF706C	255	3.0	25.4/30	100
TF706D	305	3.0	25.4/30	100
TF706E	305	3.0	25.4/30	120
TF706F	355	3.0	25.4/30	80
TF706G	355	3.0	25.4/30	100
TF706H	355	3.2	25.4/30	120
TF706J	405	3.2	25.4/30	120
TF706K	455	3.4	25.4/30	120
TF706L	505	3.4	25.4/30	100
TF706M	505	3.4	25.4/30	120
TF706N	610	3.4	25.4/30	120

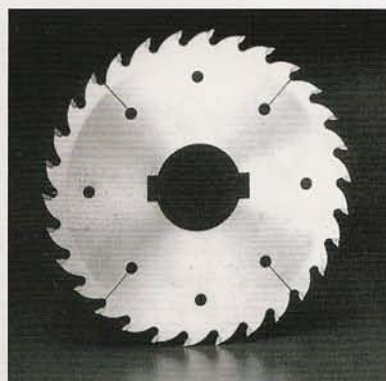
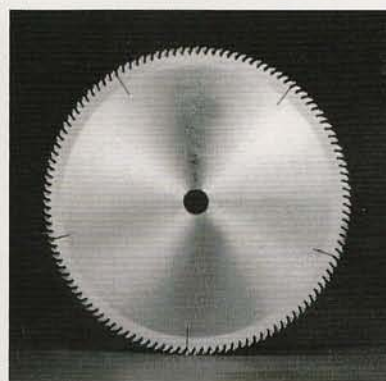
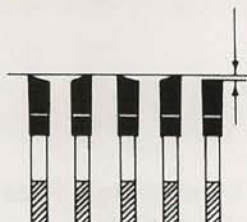

For Rip And Multiple Rip Saw

ITEM No.	ϕD	Thickness	ϕd	Z
TF706P	255	2.2	50/70	30
TF706Q	255	2.6	50/70	30
TF706R	255	3.0	50/70	30
TF706S	305	2.6	50/70	36
TF706T	305	3.0	50/70	36
TF706U	355	3.0	50/70	36

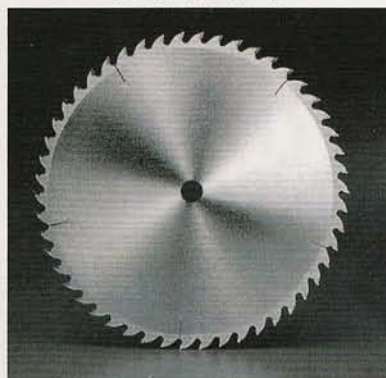
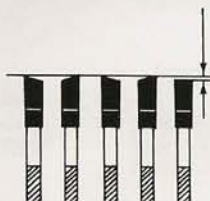

For Panel Saw

ITEM No.	ϕD	Thickness	ϕd	Z
TF706V	305	3.0	25.4	100
TF706X	355	3.2	25.4	50
TF706Y	355	3.2	25.4	60
TF706Z	355	3.2	25.4	80



TF707 Woodworking Drill Bit

Woodworking Drill Bit

TF707

TF707A



High Speed Steel Straight Flute
Two Flute or Three Flute
Drill Dia:6.0~16mm



TF707E

High Speed Steel
Four Spiral Flute
Drill Dia:8.0~32mm



TF707B



High Speed Steel Straight Flute
Four Flute
Drill Dia:8.0~16mm



TF707F

High Speed Steel Spiral Flute LH. or RH. Cut
Drill Dia:5.0~16mm



TF707C

Newly Economic type
High Speed Steel Spiral Flute LH. or RH. Cut
Shank Dia:10mm Overall Length:75mm
Flute Length:53mm Drill Dia:5mm~18mm



TF707G

High Speed Steel
Two Spiral Flute
Shank Dia & Drill Dia:4/4.5/5/6mm

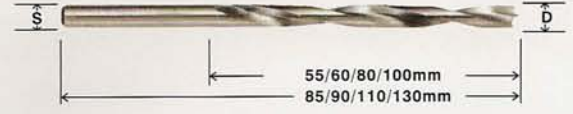

Threaded Integral Adapter



Adjustable



Drill Bit

TF707H



High Speed Steel Spiral Flute
LH. or RH. Cut
Threading:M8x1.25/M10X1.5
Overall Length:80mm/90mm
Flute Length:40mm/50mm

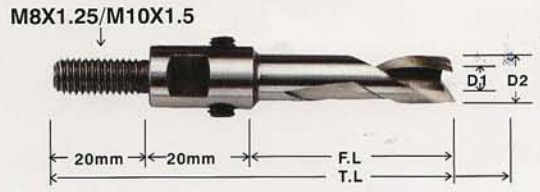

TF707D



High Speed Steel Spiral Flute



Throw Away T.C.T Tips

TF708

TF708 Throw Away T.C.T Tips

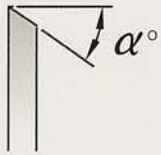

ITEM No.	L mm	W mm	T mm	C mm	α°
----------	------	------	------	------	----------------

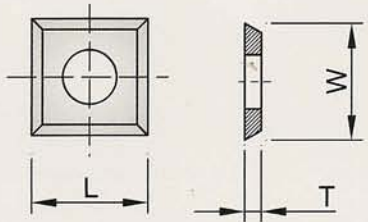

TF708A	L12	L12	1.5	—	35
--------	-----	-----	-----	---	----

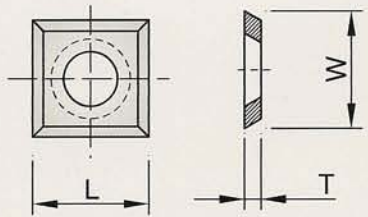

TF708B	L14	L14	2.0	—	30
TF708C	L14	L14	2.0	—	37
TF708D	L14.6	L14.6	2.5	—	30
TF708E	L15	L15	2.5	—	30
TF708F	L15	L15	2.5	—	37

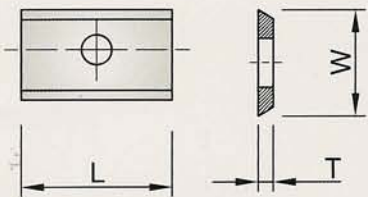

TF708G	L20	L12	1.5	—	35
--------	-----	-----	-----	---	----

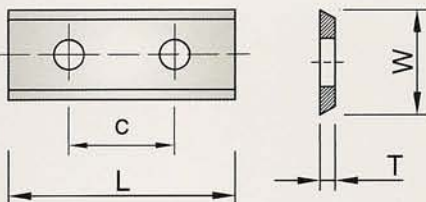

TF708H	L30	L12	1.5	14	35
TF708J	L30	L12	2.5	14	35
TF708K	L50	L12	1.5	26	35

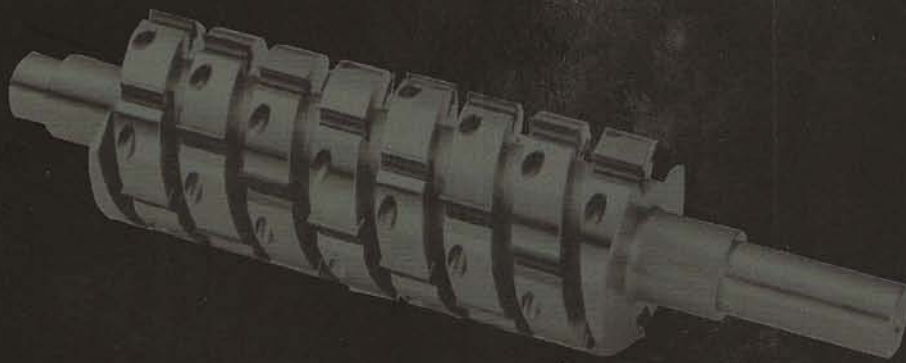

HOLYTEK
I SVERIGE AB

TRÄBEARBETNINGSMASKINER

Sten Göran Fagerman

Adress: Buttorp 105, 512 91 SEXDREGA
Tel: 0325-62 55 47 • Fax: 0325-62 55 00 • Biltfn: 0707-26 36 72
e-post: info@holYTEK.se • www.holyTEK.se



TONG FONG CUTTERS CO.,LTD.

No.17,Lane 426,Pei Yang Rd.,Feng Yuan, Taichung,Taiwan, R.O.C
TEL:886-4-25228562 • 25228683
FAX:886-4-25281127

[Http://www.tongfong.com.tw](http://www.tongfong.com.tw)
E-mail:tfcutter@ms47.hinet.net